

LABORATORY STANDS
PARTS IDENTIFICATION & INSTRUCTIONS

TEL 508-946-6200 or 800-628-8139 FAX 508-946-6262
www.brookfieldengineering.com

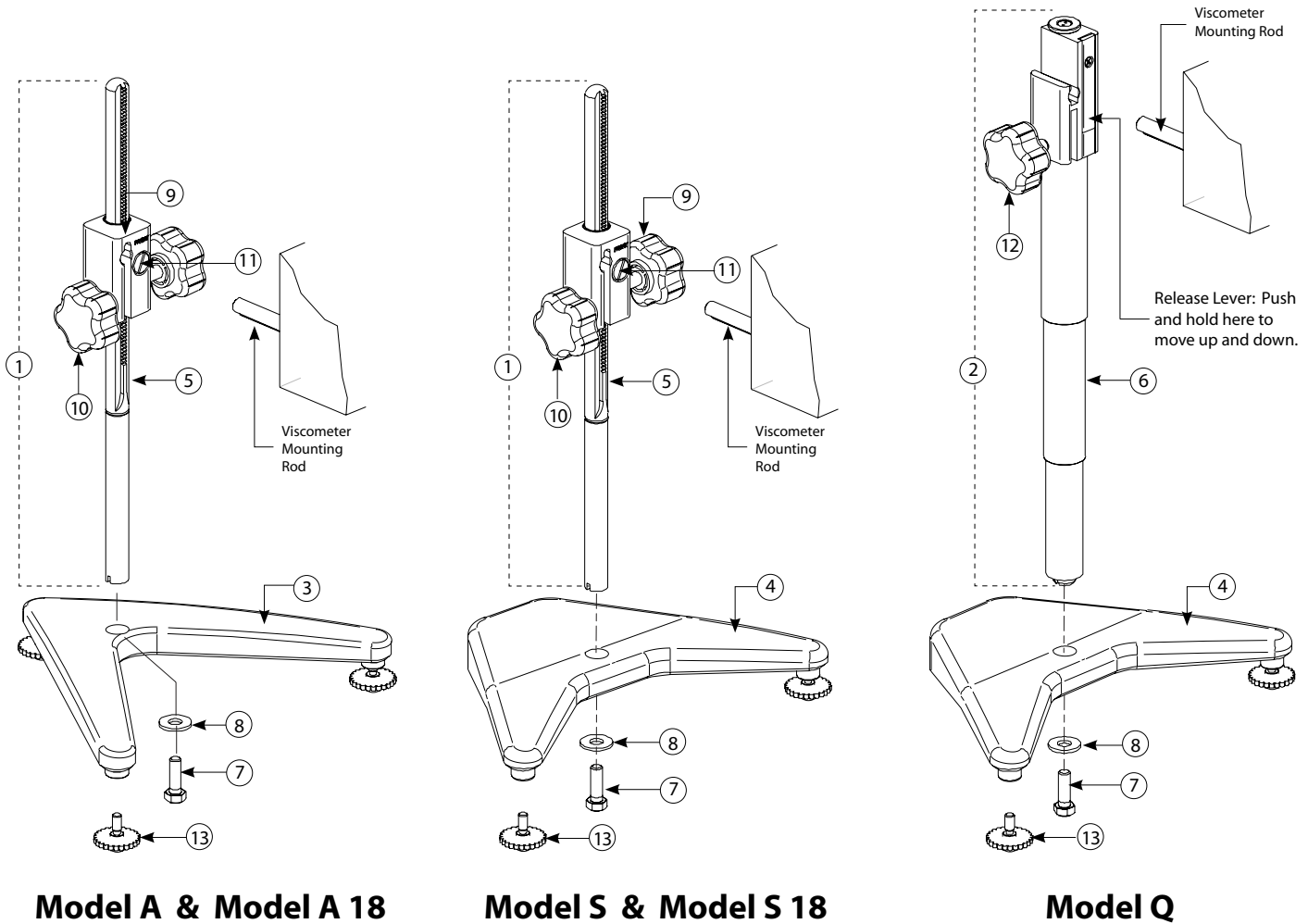

Model A & Model A 18

Model S & Model S 18

Model Q

Item	Part Number	Description	Qty.
1	VS-CRA-14S Or VS-CRA-18S	Rod (14") and Clamp Assembly (Model A & S) [†] Rod (18") and Clamp Assembly (Model A 18 and Model S 18) [†]	1 1
2	VSQA-001Y	Rod and Clamp Assembly (Model Q) [†]	1
3	VS-1Y	Base, Model A (includes 3 VS-3 leveling screws)	1
4	VS-2Y	Base, Models S and Q (includes 2 VS-3 leveling screws)	1
5	N/A	14" or 18" Upright Rod (Model A & S)	1

[†]Includes screw and washer (Items 7 and 8)

Item	Part Number	Description	Qty.
6	N/A	Upright Rod (Model Q)	1
7	50S311832S01B	Screws, 5/16 - 18 x 1" lg. slotted head	1
8	502028071S33B	Flat washer 5/16 x 7/8 x .071"	1
9	N/A	Universal Lab Stand Clamp Assembly	1
10	VS-41Y	Knob Assembly	1
11	N/A	Tension screw	1
12	N/A	Knob Assembly (Model Q)	1
13	VS-3	Leveling Screws, Model A, S and Q	3/2/2

N/A Not for individual purchase

Model A & Model A 18

Model A Lab Stand - Comes with 14" rod (VS-CRA-14S). Used with Dial and DV-E viscometers.

Model A 18 Lab Stand - Comes with 18" rod (VS-CRA-18S). Optional choice when additional height is required.

UNPACKING

Check to see that all the components are received with no concealed damage:

- 1 VS-1 Base with three leveling screws
- 1 VS-CRA-14S (Model A) or VS-CRA-18S (Model A 18) Rod and clamp assembly with one mounting screw and washer.

ASSEMBLY

1. Remove the mounting screw and washer from the upright rod. Place the rod and clamp assembly into the hole in the top of the base.
2. Position the rod and clamp assembly so that the clamp assembly has the "FRONT" marking facing forward.
3. While holding the rod and base together, insert the screw and washer as shown and tighten securely.
4. Adjust the tension screw so that the clamp assembly is not loose on the upright rod.

VISCOMETER MOUNTING AND USE

Insert the Viscometer mounting rod into the hole (with the cut-away slot) in the clamp assembly. Adjust the viscometer level until the bubble level is centered and tighten the clamp knob (clockwise). Use the leveling screws to "fine" adjust the viscometer level.

 **CAUTION:** Do not tighten the clamp knob unless the viscometer mounting rod is inserted in the clamp assembly.

Model S & Model S 18

Model S Lab Stand - Comes with 14" rod (VS-CRA-14S). Used with DV-1 Prime and DV-II+ Pro Viscometers.

Model S 18 Lab Stand - Comes with 18" rod (VS-CRA-18S). Optional choice when additional height is required.

UNPACKING

Check to see that all the components are received with no concealed damage:

- 1 VS-2Y Base with two leveling screws
- 1 VS-CRA-14S (Model S) or VS-CRA-18S (Model S 18) Rod and clamp assembly with one mounting screw and washer.

ASSEMBLY

1. Remove the mounting screw and washer from the upright rod. Place the rod and clamp assembly into the hole in the top of the base.
2. Position the rod and clamp assembly until the slot on the bottom of the rod intersects the pin located in the base.

Note: Be sure the clamp assembly has the "FRONT" marking facing forward.

3. While holding the rod and base together, insert the screw and washer as shown and tighten securely.
4. Adjust the tension screw so that the clamp assembly is not loose on the upright rod.

VISCOMETER MOUNTING AND USE

Insert the Viscometer mounting rod into the hole (with the cut-away slot) in the clamp assembly. Adjust the viscometer level until the bubble level is centered and tighten the clamp knob (clockwise). Use the leveling screws to "fine" adjust the viscometer level.

 **CAUTION:** Do not tighten the clamp knob unless the viscometer mounting rod is inserted in the clamp assembly.

Model Q

Model Q Lab stand - Comes with 14" rod (VSQA-001Y). Used with DV-II+ Pro Extra. Also available as optional choice for other viscometers when easier up/down movement of viscometer head is desired.

 **CAUTION:** The Model Q upright rod is a spring-loaded, non-serviceable device. Do not disassemble the clamp and upright rod assembly.

UNPACKING

Check to see that all the components are received with no concealed damage:

- 1 VS-2Y Base with two leveling screws
- 1 VSQA-001Y Clamp and upright rod assembly with one mounting screw and washer

ASSEMBLY

1. Remove the mounting screw and washer from the upright rod. Place the rod and clamp assembly into the hole in the top of the base with the release lever facing forward.
2. Position the rod and clamp assembly until the slot on the bottom of the rod intersects the pin located in the base.
3. While holding the rod and base together, insert the screw and washer as shown and tighten securely.

VISCOMETER MOUNTING AND USE

Insert the viscometer mounting rod into the cutaway slot of the clamp assembly. Adjust the instrument until the viscometer/rheometer bubble level is centered and tighten the clamp knob. Use the base leveling screws to "fine" adjust the instrument level.

 **CAUTION:** Do not tighten the clamp knob unless the viscometer mounting rod is inserted in the clamp assembly.

Push the release lever on the clamp assembly. Move viscometer/rheometer head to desired height and release lever.

Elevate your sample container, if necessary, to ensure that the proper spindle immersion is achieved.