

BROOKFIELD THERMOSEL ACCESSORY

Operating Instructions

Manual No. M94-204-J1213



with offices in: Boston • Chicago • London • Stuttgart • Guangzhou

BROOKFIELD ENGINEERING LABORATORIES, INC.
11 Commerce Boulevard, Middleboro, MA 02346 USA
TEL 508-946-6200 or **800-628-8139** (USA excluding MA)
FAX 508-946-6262 INTERNET <http://www.brookfieldengineering.com>

TABLE OF CONTENTS

I. INTRODUCTION	5
I.1 Utilities.....	5
I.2 Specifications.....	5
I.3 Safety Symbols and Precautions	6
I.4 Operation	7
I.5 General	10
I.6 Viscosity Measurements	10
I.7 Clean-Up.....	13
Appendix A - Viscosity Ranges/Spindle Factors.....	14
Appendix B - High Temperature Calibration Fluids.....	19
Appendix C - Disposable Sample Chambers	20
Appendix D - Solid Shaft Spindle Options	22
Appendix E - Conversion Table: Centigrade and Fahrenheit.....	23
Appendix F - Online Help and Additional Resources.....	24
Appendix G - Warranty	25

I. INTRODUCTION

NOTE: These instructions apply to both the Standard and EZ Lock versions.

The Brookfield Thermosel System consists of a Brookfield Viscometer or Rheometer with related accessories to accurately measure the viscosity of liquids at elevated temperatures. Viscosity measurements are obtained using coaxial cylinder geometry. Temperature is controlled by a solid state, triac output, Proportioning Controller which maintains the spindle, chamber, and sample material at the desired temperature.

The system is designed for measuring liquid viscosities over a temperature range from 40°C (104°F) to 300°C (572°F). The designed viscosity range is from 3 cP to 80,000,000 cP depending upon the viscometer and SC4 spindle used.

Please note that all references made herein to digital viscometers would also apply to DV-III+, DV-III Ultra and DV3T Rheometers.

I.1 Utilities

Input Voltage: 115 VAC or 230 VAC
Input Frequency: 50/60 Hz
Current Rating: 15 Amps
Main supply voltage fluctuations are not to exceed $\pm 10\%$ of the nominal supply voltage.

I.2 Specifications

Operating Environment: 5°C to 40°C temperature range (32°F to 104°F)
Relative Humidity: 20% - 80%: non-condensing atmosphere

CE Certification: This product conforms to the general safety requirements for electrical equipment, for measurement control and laboratory use. This product conforms to international standards which specify minimum requirements for immunity and emissions regarding electromagnetic compatibility (EMC) for electrical equipment intended for professional, industrial, process and educational use.

I.3 Safety Symbols and Precautions

Safety Symbols



(Caution hot surface symbol) Caution some surfaces may be hot.



(Caution symbol)

Refer to the manual for specific warning or caution information to avoid personal injury or damage to the instrument.

Precautions



(Caution symbol)

If this instrument is used in a manner not specified by the manufacturer, the protection provided by the instrument may be impaired.



(Caution symbol)

This instrument is not intended for use in a potentially hazardous environment.



(Caution symbol)

In case of emergency, turn off all of the system components and then disconnect all electrical cords from the wall outlet.



(Caution symbol)

The user should ensure that the substances placed under test do not release poisonous, toxic or flammable gases at the temperatures which they are subjected to during the testing.

I.4 Operation

Viscometer and Stand

The instrumentation should be placed on a firm level surface near a 15 amp, 115 or 230 volt, 50 or 60 Hz grounded AC electrical service, as required. A cooling water supply and drain arrangement is also recommended for cooling the thermo-container with optional cooling plug assembly.

Set up the viscometer stand by connecting the upright rod with clamp attached into the base. Screw the leveling screws into position on the base. (Refer to the assembly instruction supplied with your lab stand.) Attach the viscometer to the stand by inserting it into the clamp; level the viscometer and position it **centered** between the stand legs. Raise the viscometer on the lab stand upright rod so that there will be sufficient room to attach the alignment bracket. Check that the power switch is **OFF** and plug the viscometer power cord into the appropriate electrical service.

Alignment Bracket

Attach the alignment bracket to the rear of the viscometer pivot cup, securing it tight with the knurled screw. (Refer to Figure I-2).

Thermo-Container, Sample Chamber, Safety Guard

Using the three (3) leveling screws in the thermo-container base, to level the base.

Check that the perforated safety guard is flush onto the base of the thermo-container.

Using the extracting tool, insert the chamber into the thermo-container. Rotate the chamber until it drops and locks in place prohibiting further rotation.

Controller and Probe

Set the controller on a level surface adjacent to the thermo-container. Insert the male plug (three-prong) from the thermo-container braided cord into the socket on the back of the controller (turn and lock connection). Insert the four-inch stainless steel probe (Resistance Thermometer) into the hole in the thermo-container located directly above the braided cord. Plug the other end of the probe into the connector located on the back of the controller. To remove the probe, depress the spring clip and carefully slide probe out. This removal procedure should not be followed if the thermo-container is at a temperature above 100°F (37°C). Cool the thermo-container first.



If the probe is not inserted in the thermo-container and the controller is turned on, the thermo-container will cease to heat and the controller will give an audible signal!

Set the controller power switch to the **OFF** position.

Plug the controller power cord into a 115V, 50/60 Hz or 230 V, 50/60 Hz grounded AC power supply, as required.

System Alignment & Spindle Insertion

Looking down on the viscometer, level the stand base by adjusting the leveling screws until the bubble is centered.

Position the thermo-container and base between the viscometer stand legs and adjust the three (3) knurled screws until the bubble is centered.

Lower the viscometer until the tips of the alignment bracket (see Figure I-1) **just** touch the horizontal surface of the locating ring, making contact directly behind the vertical curve. Raise the viscometer, positioning the tips of the alignment bracket about 1/16 inch above the horizontal surface behind the locating ring. **An etched line on the back of the locating ring is the 1/16 inch reference point.**

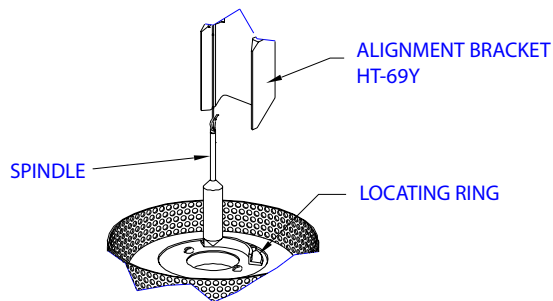

Figure I-1

NOTE: Do not forcibly displace the alignment bracket!

Thermosels and Viscometers are factory-aligned prior to shipment. If viscosity measurements are suspect, first check system calibration using suitable viscosity standard fluids (see Appendix B). Add the appropriate volume to the sample container (see Appendix A, Range Tables, for volume requirement; see viscometer operating manual for calibration procedures).

- If using a spindle that requires an extension link and coupling nut, attach one end of the link to the spindle and the other to the coupling nut. Carefully lower the spindle by the coupling nut and link into the sample chamber. While pushing up gently on the pivot screw that protrudes from the bottom of the viscometer, thread the coupling nut onto the viscometer. **Note that the spindle has a left-hand thread.**
- If using an EZ-Lock spindle, attach the spindle to the viscometer by raising the spring-loaded sleeve at the base of the viscometer pivot cup and inserting the spindle so that the bottom of the coupling is flush with the bottom of the sleeve.
- If using a solid shaft (SC4-**BS) spindle, carefully lower the spindle into the sample chamber. While pushing up gently on the spindle coupling nut that protrudes from the bottom of the viscometer, thread the spindle onto the viscometer. **Note that the spindles have a left-hand thread.**

Place the insulating cap over the sample chamber inlet.

Brookfield Thermosel with DV2T Viscometer

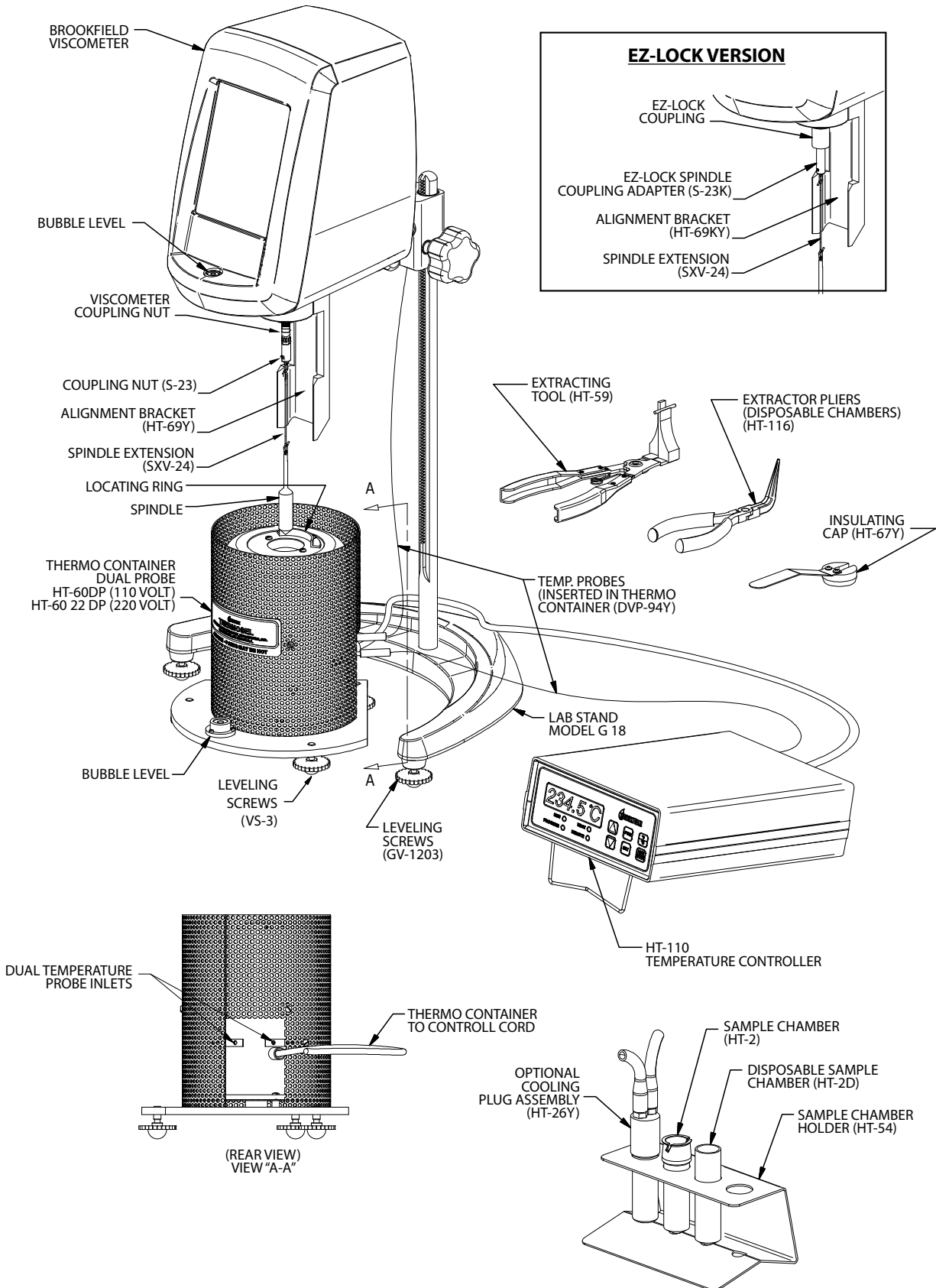

Figure I-2

I.5 General

The operator should become familiar with the alignment procedure so that the system can be safely aligned and operated at elevated temperatures.

The system is designed to operate in the temperature range from 40°C (104°F) to a maximum of 300°C (572°F). Control of test sample temperature is possible in this range with accuracy as follows:

Temperature Range	Temperature Accuracy
40°C to +150°C	±1.0°C
+150°C to +300°C	±2.0°C

NOTE: The lower limit of control is approximately 40°C (104°F). The upper limit of precise control is 300°C (572°F). This is determined not by the controller-heat element capabilities, but by design of the spindle, sample chamber, thermo-container, and the proximity of the viscometer to the thermo-container.



USE OF THE SYSTEM ABOVE 300°C COULD RESULT IN DAMAGE TO THE THERMO-CONTAINER AND TO THE VISCOMETER.

The controller will bring the thermo-container to elevated set point temperature in approximately 30 minutes. However, lowering the temperature from the elevated set point can be quite time consuming. Approximately four hours is required for the thermo-container to cool from 260°C (500°F) to 37°C (100°F). Using the optional cooling plug (HT-26Y) this temperature reduction can be accomplished in about 20 minutes. Familiarization with the temperature controller instructions should be made at this time.

Refer to Appendix A for viscosity range data, spindle factors (for use with Dial Reading Viscometers), and test volume sample size. This information is to be used when obtaining viscosity measurements.

I.6 Viscosity Measurements

Samples That Are Liquid At Ambient Temperature

With the instrumentation assembled and familiarization completed, the following steps are recommended for taking viscosity measurements of samples which are liquid at ambient temperature:

1. Remove the insulating cap; for a standard spindle, unthread the coupling nut and remove the spindle; for an EZ-Lock spindle, raise the spring-loaded sleeve and remove the spindle.
2. Raise the viscometer to the highest level on the stand.
3. Remove the sample chamber (HT-2 or HT-2D) using the extracting tool (HT-59 or HT-116 respectively) and place it in the sample chamber holder (HT-54).

4. Using a syringe, graduated cylinder, or other suitable measuring device, pour into the sample chamber the volume of liquid sample specified on the range table in Appendix A.
5. Using an extracting tool, put the filled sample chamber back into the thermo-container by rotating the chamber until it drops and locks in place.
6. Lower the viscometer and align the thermo-container.
7. Lower the spindle into the chamber and connect the link and coupling nut (S-23) to viscometer coupling nut by lifting the viscometer shaft up slightly while screwing on the S-23. (Note left-hand thread). Or for an EZ-Lock viscometer, connect the spindle, link and coupling nut (S-23K). Lower the spindle into the chamber. Raise the spring-loaded sleeve at the base of the viscometer and insert the coupling nut (S-23K). Slide the sleeve back down to hold the spindle in place.
8. Check that the liquid level is approximately 1/8 inch above the conical surface on the spindle shaft. **Do not overfill.**
9. Replace the insulating cap.
10. Turn on the temperature controller and adjust the set point to the desired temperature.

NOTE: The set point temperature will be denoted by a steady display on the controller, along with the steady flashing of the heater "ON" light.

One option for sample materials that are not thixotropic or pseudoplastic is to turn **ON** the viscometer motor and leave it running during the equilibrium period. The rotating spindle provides agitation which helps reduce temperature equilibrium time and temperature gradients within the test sample.

11. After the thermo-container, spindle, chamber, and test sample have reached temperature equilibrium, viscosity readings at different speeds may be obtained.

Samples That Are Not Liquid At Ambient Temperature

There are several alternative approaches toward testing samples that are solid or semi-solid at ambient (room) temperature. The main concerns are: **First - safety; Second - keeping test material *IN* the sample chamber and *OUT OF* the thermo-container "well."** The thermo-container can be preheated without the sample chamber and test material if desired.

The following steps are recommended for taking viscosity measurements of test samples that are liquid only at elevated temperatures.

1. The instrumentation should be assembled without the insertion of the sample chamber, spindle, and insulator cap.
2. Set the controller to the desired temperature.
3. Weigh into the sample chamber the amount of test sample which in the liquid state will be equivalent to the test volume required. It is helpful to know the density of the sample material.
4. Place the sample chamber into the thermo-container and proceed, following the steps outlined for liquid samples at ambient temperature, starting on Page 6.

With the sample chamber removed, the thermo-container can be cooled by inserting the optional cooling plug (HT-26Y) into the sample chamber well and circulating a cooling medium (tap water) through it.



Water must be circulating through the cooling plug at all times prior to and during the cooling period.

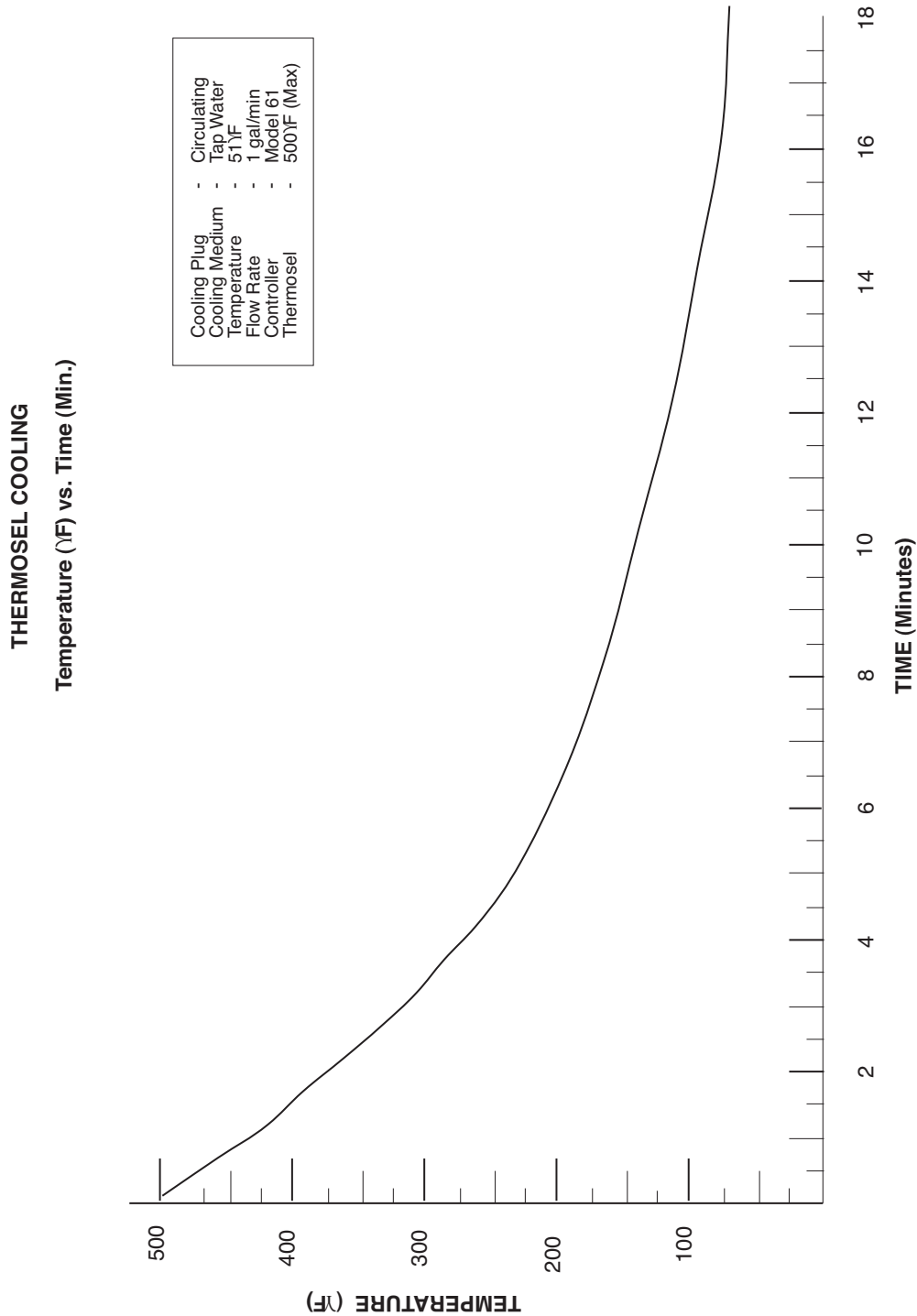

Figure I-3

I.7 Clean-Up

Cleaning

Using the extracting tool, lift the chamber out of the thermo-container and pour out the sample material. The spindle and chamber are made of stainless steel which can be cleaned with most commercial solvents. They should not come in contact with Sulfuric Acid; Hydrofluoric Acid; Ferric Chloride or Hydrochloric Acid solutions. Use mechanical action as required to scrape out the chamber.

Disposable sample chambers and spindles do not require any type of cleaning and may be discarded after use.

APPENDIX A — VISCOSITY RANGES / SPINDLE FACTORS

Thermosel Viscosity Range Data

Dial Viscometers

Spindle	Viscosity (cP)		Shear Rate sec ⁻¹	Sample Volume (mL)
	LVT			
SC4-18	5	- 10,000	1.32N	8.0
SC4-31	50	- 100,000	0.34N	10
SC4-34	100	- 200,000	0.28N	9.5
HT-DIN-81	5.7	- 11,400	1.29N	7.0

Spindle	Viscosity (cP)		Shear Rate sec ⁻¹	Sample Volume (mL)
	RVT			
SC4-21	50	- 100,000	0.93N	8.0
SC4-27	250	- 500,000	0.34N	10.5
SC4-28	500	- 1,000,000	0.28N	11.5
SC4-29	1,000	- 2,000,000	0.25N	13.0
HT-DIN-81	36.5	- 73,000	1.29N	7.0

Spindle	Viscosity (cP)		Shear Rate sec ⁻¹	Sample Volume (mL)
	HAT	HBT		
SC4-21	100 - 200,000	400 - 800,000	0.93N	8.0
SC4-27	500 - 1,000,000	2,000 - 4,000,000	0.34N	10.5
SC4-28	1,000 - 2,000,000	4,000 - 8,000,000	0.28N	11.5
SC4-29	2,000 - 4,000,000	8,000 - 16,000,000	0.25N	13.0
HT-DIN-81	73 - 146,000	292 - 584,000	1.29N	7.0

N = RPM

DV-E and DV-I Series Viscometers

Spindle	Viscosity (cP)		Shear Rate sec ⁻¹	Sample Volume (mL)
	LV DV-E LV DV-I PRIME			
SC4-18	3	10,000	1.32N	8.0
SC4-31	30	100,000	0.34N	10
SC4-34	60	200,000	0.28N	9.5
HT-DIN-81	3.42	11,400	1.29N	7.0

Spindle	Viscosity (cP)			Shear Rate sec ⁻¹	Sample Volume (mL)
	RVDV-E RVDV-I PRIME	HADV-E HADV-I PRIME	HBDV-E HBDV-I PRIME		
SC4-21	50 - 170,000	100 - 334,000	400 - 1,336,000	0.93N	8.0
SC4-27	250 - 830,000	500 - 1,660,000	2,000 - 6,640,000	0.34N	10.5
SC4-28	500 - 1,660,000	1,000 - 3,320,000	4,000 - 13,280,000	0.28N	11.5
SC4-29	1,000 - 3,330,000	2,000 - 6,660,000	8,000 - 26,640,000	0.25N	13.0
HT-DIN-81	36.5 - 121,700	73 - 243,300	292 - 973,300	1.29N	7.0

N = RPM

DV2T and DV-II Series Viscometers

Spindle	Viscosity (cP)		Shear Rate sec ⁻¹	Sample Volume (mL)
	LV Torque			
SC4-18	3	30,000	1.32N	8.0
SC4-31	15	300,000	0.34N	10
SC4-34	30	600,000	0.28N	9.5
HT-DIN-81	3.42	34,200	1.29N	7.0

Spindle	Viscosity (cP)			Shear Rate sec ⁻¹	Sample Volume (mL)
	RV Torque	HA Torque	HB Torque		
SC4-21	25 - 500,000	50 - 1,000,000	200 - 4,000,000	0.93N	8.0
SC4-27	125 - 2,500,000	250 - 5,000,000	1,000 - 20,000,000	0.34N	10.5
SC4-28	250 - 5,000,000	500 - 10,000,000	2,000 - 40,000,000	0.28N	11.5
SC4-29	500 - 10,000,000	1,000 - 20,000,000	4,000 - 80,000,000	0.25N	13.0
HT-DIN-81	18.25 - 365,000	36.5 - 730,000	146 - 2,920,000	1.29N	7.0

N = RPM

DV3T & DV-III Series Rheometers

Spindle	Viscosity (cP)	Shear Rate sec ⁻¹	Sample Volume (mL)
	LV Torque		
SC4-18	3 - 30,000	1.32N	8.0
SC4-31	12 - 300,000	0.34N	10
SC4-34	24 - 600,000	0.28N	9.5
HT-DIN-81	3.42 - 34,200	1.29N	7.0

Spindle	Viscosity (cP)			Shear Rate sec ⁻¹	Sample Volume (mL)
	RV Torque	HA Torque	HB Torque		
SC4-21	20 - 500,000	40 - 1,000,000	160 - 4,000,000	0.93N	8.0
SC4-27	100 - 2,500,000	200 - 5,000,000	800 - 20,000,000	0.34N	10.5
SC4-28	200 - 5,000,000	400 - 10,000,000	1,600 - 40,000,000	0.28N	11.5
SC4-29	400 - 10,000,000	800 - 20,000,000	3,200 - 80,000,000	0.25N	13.0
HT-DIN-81	14.6 - 365,000	29.2 - 730,000	117 - 2,920,000	1.29N	7.0

N = RPM

Thermosel Spindle Factors

SPEED (RPM)	LV VISCOMETER SPINDLE NUMBER		
	18	31	34
60	0.5	5	10
30	1	10	20
12	2.5	25	50
6	5	50	100
3	10	100	200
1.5	20	200	400
0.6	50	500	1K
0.3	100	1K	2K

SPEED (RPM)	RV VISCOMETER SPINDLE NUMBER			
	21	27	28	29
100	5	25	50	100
50	10	50	100	200
20	25	125	250	500
10	50	250	500	1K
5	100	500	1K	2K
4	125	625	1.25K	2.5K
2.5	200	1K	2K	4K
2	250	1.25K	2.5K	5K
1	500	2.5K	5K	10K
0.5	1K	5K	10K	20K

SPEED (RPM)	HA VISCOMETER SPINDLE NUMBER			
	21	27	28	29
100	10	50	100	200
50	20	100	200	400
20	50	250	500	1K
10	100	500	1K	2K
5	200	1K	2K	4K
2.5	400	2K	4K	8K
2	500	2.5K	5K	10K
1	1K	5K	10K	20K
0.5	2K	10K	20K	40K

SPEED (RPM)	HB VISCOMETER SPINDLE NUMBER			
	21	27	28	29
100	40	200	400	800
50	80	400	800	1.6K
20	200	1K	2K	4K
10	400	2K	4K	8K
5	800	4K	8K	16K
2.5	1.6K	8K	16K	32K
2	2K	10K	20K	40K
1	4K	20K	40K	80K
0.5	8K	40K	80K	160K

K=1000 To calculate viscosity in centipoise (cP), multiply the dial reading by the factor corresponding to the viscometer spindle and speed combination utilized.

APPENDIX B — HIGH TEMPERATURE CALIBRATION FLUIDS

These fluids are recommended for verifying the calibration of the Brookfield Thermosel System.

Fluid	Temperature		Nominal Viscosity Centipoise (mPa•s)
	°C	°F	
HT - 30,000	25.0	77	30,000
	93.3	200	9,000
	149.0	300	4,500
HT-60,000	25.0	77	60,000
	93.3	200	18,000
	149.0	300	9,000
HT-100,000	25.0	77	100,000
	93.3	200	30,000
	149.0	300	15,000

The viscometer calibration is verified first. A regular* "disc" spindle should be used to test the HT fluid in its jar at 25.0°C or 77°F. Please refer to the appropriate viscometer operation manual for instructions.

The Thermosel System and its appropriate spindle are then used to measure the HT fluid's viscosity at 200 and 300°F.

Contact Brookfield Engineering Laboratories or an authorized dealer/distributor/representative in your area for purchase of these fluids.

* Standard spindles supplied with viscometer.

APPENDIX C — DISPOSABLE SAMPLE CHAMBERS AND SPINDLES

Disposable Sample Chambers are intended for use with difficult to clean materials, or in busy laboratories where the low cost disposable chamber may improve productivity. Also available are disposable SC4-27D spindles for use with the Brookfield Thermosel.

The HT-2DB disposable chambers are inserted into or removed from HT-60DP or HT-60ADP Thermo Container using the HT-116 pliers as shown in **Figure C-1**.

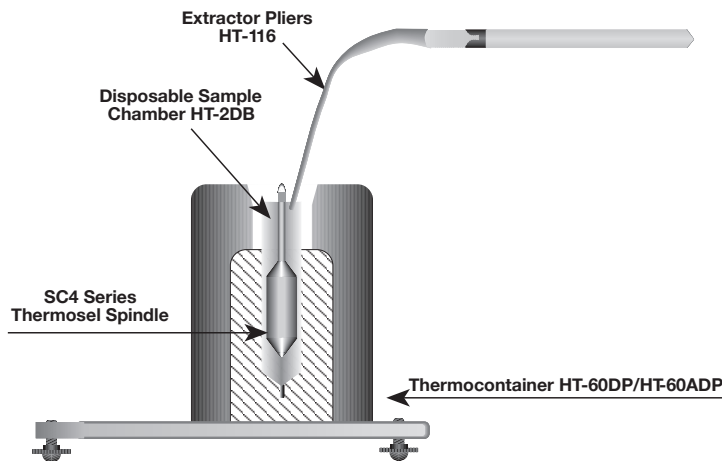

Figure C-1

Replacement disposable chambers are available in packages of 100 chambers (Brookfield Part No. HT-2DB-100). Contact Brookfield or your Brookfield agent for pricing and delivery information.

A package of five disposable aluminum sample chambers (Brookfield Part No. HT-2DB) and one pair of extraction pliers (Brookfield Part No. HT-116) are supplied with each new Thermosel System.

Disposable Spindle Instructions (see Figures C-2 and C-3)

1. Loosen closer.
2. Slide disposable spindle into chuck to insertion mark.
3. Hold chuck and hand-tighten closer.
4. For standard assembly, attach the assembly (spindle and chuck) to the viscometer being careful to hold the pointer shaft firmly and lift up slightly. See Figure C-2.
5. For EZ-Lock assembly, attach the assembly (spindle and chuck) to the viscometer by raising the spring-loaded sleeve at the base of the viscometer pivot cup and inserting the chuck. Slide the sleeve back down to lock the assembly in place. See Figure C-3.

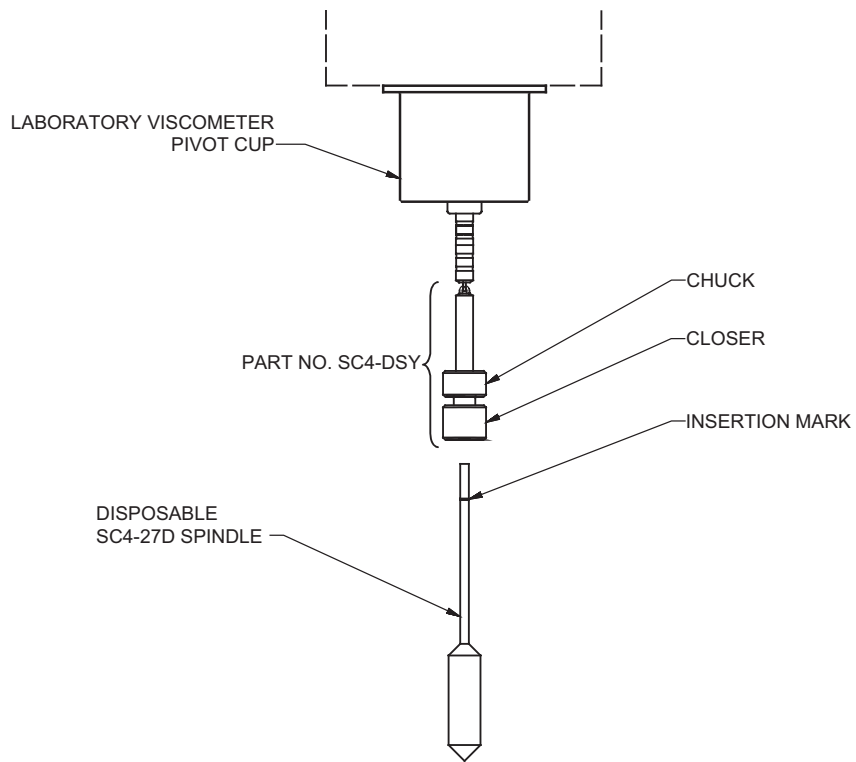

Figure C-2: Standard

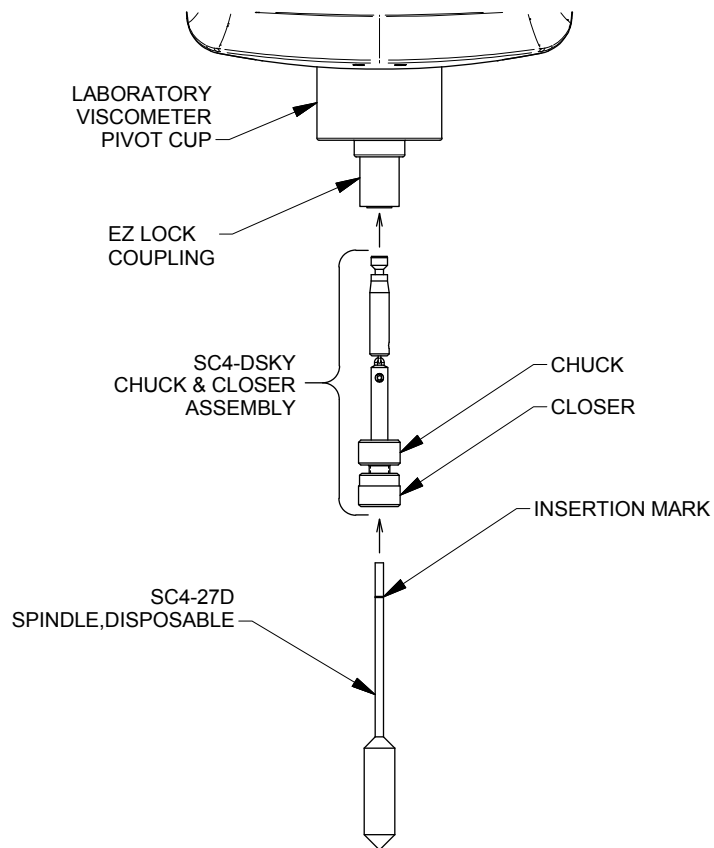

Figure C-3: EZ-Lock

APPENDIX D - SOLID SHAFT SPINDLE OPTION

Solid shaft spindles are available for use with the Brookfield Thermosel Systems. These spindles facilitate the measurement of “stiff”, slow-flowing materials such as:

***Candy base
Highly-filled epoxies***

***Pastes
Asphalts***

The solid shaft on these spindles minimizes the “walking” (eccentric rotation) experienced when measuring “stiff” materials with the standard link hanging Thermosel spindles. These spindles are directly interchangeable in viscosity range and sample volume with the standard Thermosel spindles. No modifications to the Thermosel or the viscometer are necessary. Solid shaft spindles are available, as listed:

Standard Solid Shaft Spindles	EZ-Lock Solid Shaft Spindles
SC4-27 BS	SC4-27 KBS
SC4-28 BS	SC4-28 KBS
SC4-29 BS	SC4-29 KBS
SC4-31 BS	SC4-31 KBS
SC4-34 BS	SC4-34 KBS

Contact Brookfield Engineering Laboratories or your Brookfield agent for purchase of these spindles.

APPENDIX E - CONVERSION TABLE: CENTIGRADE° and FAHRENHEIT°

Center Columns (*) are the reference temperature. °C converts to °F on the right of the reference temperature; °F converts to °C on the left of the reference temperature.

C°	*	F°	C°	*	F°	C°	*	F°	C°	*	F°	C°	*	F°
-17.8	0	32.0	11.7	53	127.4	40.6	105	221.0	69.4	157	314.6	98.3	209	408.2
-17.2	1	33.8	12.2	54	129.2	41.1	106	222.8	70.0	158	316.4	98.9	210	410.0
-16.7	2	35.6	12.8	55	131.0	41.7	107	224.6	70.6	159	318.2	99.4	211	411.8
-16.1	3	37.4	13.3	56	132.8	42.2	108	226.4	71.1	160	320.0	100.0	212	413.6
-15.6	4	39.2	13.9	57	134.6	42.8	109	228.2	71.7	161	321.8	100.6	213	415.4
-15.0	5	41.0	14.4	58	136.4	43.3	110	230.0	72.2	162	323.6	101.1	214	417.2
-14.4	6	42.8	15.0	59	138.2	43.9	111	231.8	72.8	163	325.4	101.7	215	419.0
-13.9	7	44.6	15.6	60	140.0	44.4	112	233.6	73.3	164	327.2	102.2	216	420.8
-13.3	8	46.4	16.1	61	141.8	45.0	113	235.4	73.9	165	329.0	102.8	217	422.6
-12.8	9	48.2	16.7	62	143.6	45.6	114	237.2	74.4	166	330.8	103.3	218	424.4
-12.2	10	50.0	17.2	63	145.4	46.1	115	239.0	75.0	167	332.6	103.9	219	426.2
-11.7	11	51.8	17.8	64	147.2	46.7	116	240.8	75.6	168	334.4	104.4	220	428.0
-11.1	12	53.6	18.3	65	149.0	47.2	117	242.6	76.1	169	336.2	105.0	221	429.8
-10.6	13	55.4	18.9	66	150.8	47.8	118	244.4	76.7	170	338.0	105.6	222	431.6
-10.0	14	57.2	19.4	67	152.6	48.3	119	246.2	77.2	171	339.8	106.1	223	433.4
-9.4	15	59.0	20.0	68	154.4	48.9	120	248.0	77.8	172	341.6	106.7	224	435.2
-8.9	16	60.8	20.6	69	156.2	49.4	121	249.8	78.3	173	343.4	107.2	225	437.0
-8.3	17	62.6	21.1	70	158.0	50.0	122	251.6	78.9	174	345.2	107.8	226	438.8
-7.8	18	64.4	21.7	71	159.8	50.6	123	253.4	79.4	175	347.0	108.3	227	440.6
-7.2	19	66.2	22.2	72	161.6	51.1	124	255.2	80.0	176	348.8	108.9	228	442.4
-6.7	20	68.0	22.8	73	163.4	51.7	125	257.0	80.6	177	350.6	109.4	229	444.2
-6.1	21	69.8	23.3	74	165.2	52.2	126	258.8	81.1	178	352.4	110.0	230	446.0
-5.6	22	71.6	23.9	75	167.0	52.8	127	260.6	81.7	179	354.2	110.6	231	447.8
-5.0	23	73.4	24.4	76	168.8	53.3	128	262.4	82.2	180	356.0	111.1	232	449.6
-4.4	24	75.2	25.0	77	170.6	53.9	129	264.2	82.8	181	357.8	111.7	233	451.4
-3.9	25	77.0	25.6	78	172.4	54.4	130	266.0	83.3	182	359.6	112.2	234	453.2
-3.3	26	78.8	26.1	79	174.2	55.0	131	267.8	83.9	183	361.4	112.8	235	455.0
-2.8	27	80.6	26.7	80	176.0	55.6	132	269.6	84.4	184	363.2	113.3	236	456.8
-2.2	28	82.4	27.2	81	177.8	56.1	133	271.4	85.0	185	365.0	113.9	237	458.6
-1.7	29	84.2	27.8	82	179.6	56.7	134	273.2	85.6	186	366.8	114.4	238	460.4
-1.1	30	86.0	28.3	83	181.4	57.2	135	275.0	86.1	187	368.6	115.0	239	462.2
-0.6	31	87.8	28.9	84	183.2	57.8	136	276.8	86.7	188	370.4	115.6	240	464.0
0.0	32	89.6	29.4	85	185.0	58.3	137	278.6	87.2	189	372.2	116.1	241	465.8
0.6	33	91.4	30.0	86	186.8	58.9	138	280.4	87.8	190	374.0	116.7	242	467.6
1.1	34	93.2	30.6	87	188.6	59.4	139	282.2	88.3	191	375.8	117.2	243	469.4
1.7	35	95.0	31.1	88	190.4	60.0	140	284.0	88.9	192	377.6	117.8	244	471.2
2.2	36	96.8	31.7	89	192.2	60.6	141	285.8	89.4	193	379.4	118.3	245	473.0
2.8	37	98.6	32.2	90	194.0	61.1	142	287.6	90.0	194	381.2	118.9	246	474.8
3.3	38	100.4	32.8	91	195.8	61.7	143	289.4	90.6	195	383.0	119.4	247	476.6
3.9	39	102.2	33.3	92	197.6	62.2	144	291.2	91.1	196	384.8	120.0	248	478.4
4.4	40	104.0	33.9	93	199.4	62.8	145	293.0	91.7	197	386.6	120.6	249	480.2
5.0	41	105.8	34.4	94	201.2	63.3	146	294.8	92.2	198	388.4	121.1	250	482.0
5.6	42	107.6	35.0	95	203.0	63.9	147	296.6	92.8	199	390.2	121.7	251	483.8
6.1	43	109.4	35.6	96	204.8	64.4	148	298.4	93.3	200	392.0	122.2	252	485.6
6.7	44	111.2	36.1	97	206.6	65.0	149	300.2	93.9	201	393.8	122.8	253	487.4
7.2	45	113.0	36.7	98	208.4	65.6	150	302.0	94.4	202	395.6	123.3	254	489.2
7.8	46	114.8	37.2	99	210.2	66.1	151	303.8	95.0	203	397.4	123.9	255	491.0
8.3	47	116.6	37.8	100	212.0	66.7	152	305.6	95.6	204	399.2	124.4	256	492.8
8.9	48	118.4	38.3	101	213.8	67.2	153	307.4	96.1	205	401.0	125.0	257	494.6
9.4	49	120.2	38.9	102	215.6	67.8	154	309.2	96.7	206	402.8	125.6	258	496.4
10.0	50	122.0	39.4	103	217.4	68.3	155	311.0	97.2	207	404.6	126.1	259	498.2
10.6	51	123.8	40.0	104	219.2	68.9	156	312.8	97.8	208	406.4	126.7	260	500.0
11.1	52	125.6												

APPENDIX F - ONLINE HELP AND ADDITIONAL RESOURCES

www.brookfieldengineering.com**

The Brookfield website is a good resource for additional information and self-help whenever you need it. Our website offers a selection of “how-to” videos, application notes, conversion tables, instructional manuals, material safety data sheets, calibration templates and other technical resources.

<http://www.youtube.com/user/BrookfieldEng>

Brookfield has its own YouTube channel. Videos posted to our website can be found here as well as other “home-made” videos made by our own technical sales group.

Viscosityjournal.com

Brookfield is involved with a satellite website that should be your first stop in viscosity research. This site serves as a library of interviews with experts in the viscosity field as well as Brookfield technical articles and conversion charts. Registration is required, so that you can be notified of upcoming interviews and events, however, this information will not be shared with other vendors, institutions, etc..

Article Reprints

- Available in Print Only
- Brookfield has an extensive library of published articles relating to viscosity, texture and powder testing. Due to copyright restrictions, these articles cannot be emailed. Please request your hardcopy of articles by calling our customer service department directly or by emailing: marketing@brookfieldengineering.com
- Available Online
- Brookfield has a growing number of published articles that can be downloaded directly from the Brookfield website. These articles can be found on our main site by following this path: <http://www.brookfieldengineering.com/support/documentation/article-reprints>

More Solutions to Sticky Problems

Learn more about viscosity and rheology with our most popular publication. This informative booklet will provide you with measurement techniques, advice and much more. It's a must-have for any Brookfield Viscometer or Rheometer operator. More Solutions is available in print and also as a downloadable pdf on the Brookfield website by following this path: <http://www.brookfieldengineering.com/support/documentation>

Training/Courses

Whether it is instrument-specific courses, training to help you better prepare for auditing concerns, or just a better understanding of your methods, who better to learn from than the worldwide leaders of viscosity measuring equipment? Visit our Services section on our website to learn more about training.

** Downloads will require you to register your name, company and email address. We respect your privacy and will not share this information outside of Brookfield.

APPENDIX G - WARRANTY

Brookfield Viscometers are guaranteed for one year from date of purchase against defects in materials and workmanship. They are certified against primary viscosity standards traceable to the National Institute of Standards and Technology (NIST). The Viscometer must be returned to Brookfield Engineering Laboratories, Inc. or to the Brookfield dealer from whom it was purchased for a warranty service. Transportation is at the purchaser's expense. The Viscometer should be shipped in its carrying case together with all spindles originally provided with the instrument. If returning to Brookfield, please contact us for a return authorization number prior to shipping.

*For a copy of the Repair Return Form, go to the Brookfield website,
www.brookfieldengineering.com*

For repair or service in the **United States** return to:

Brookfield Engineering Laboratories, Inc.
11 Commerce Boulevard
Middleboro, MA 02346 U.S.A.
Telephone: (508) 946-6200 FAX: (508) 946-6262
www.brookfieldengineering.com

For repair or service outside the United States consult Brookfield Engineering Laboratories, Inc. or the dealer from whom you purchased the instrument.

For repair or service in the **United Kingdom** return to:

Brookfield Viscometers Limited
Brookfield Technical Centre
Stadium Way
Harlow, Essex CM19 5GX, England
Telephone: (44) 1279/451774 FAX: (44) 1279/451775
www.brookfield.co.uk

For repair or service in **Germany** return to:

Brookfield Engineering Laboratories Vertriebs GmbH
Hauptstrasse 18
D-73547 Lorch, Germany
Telephone: (49) 7172/927100 FAX: (49) 7172/927105
www.brookfield-gmbh.de

For repair or service in **China** return to:

Guangzhou Brookfield Viscometers and Texture Instruments Service Company Ltd.
Suite 905, South Tower, Xindacheng Plaza
193 Guangzhou Da Dao Bei, Yuexiu District
Guangzhou, 510075 P. R. China
Telephone: (86) 20/3760-0548 FAX: (86) 20/3760-0548
www.brookfield.com.cn

On-site service at your facility is also available from Brookfield. Please contact our Service Department in the United States, United Kingdom, Germany or China for details.