



Operation Instructions

HPQA
Helipath Quick Action Stand

PROPRIETARY RIGHTS NOTICE

This manual contains valuable information and material developed by AMETEK Brookfield for use with the Helipath Quick Action Stand. No part of this manual can be reproduced or transmitted in any form or by any means, electronic, mechanical, or otherwise. This includes photocopying and recording or in connection with any information storage or retrieval system without the express written permission of
AMETEK Brookfield.

ALL RIGHTS RESERVED

© 2024 AMETEK Brookfield. All rights reserved.

TABLE OF CONTENTS

1. INTRODUCTION	5
1.1 Components.....	6
1.2 Utilities	6
1.3 Component Diagram.....	7
1.4 Specifications	8
1.5 Installation	9
1.6 Safety Symbols and Precautions.....	10
1.7 Preventative Maintenance and Cleaning.....	11
2. GETTING STARTED	12
2.1 Power up.....	12
2.2 Start Up Screen	12
2.3 Main Menu & Joystick.....	13
2.3.1 Homing.....	13
2.3.2 Test Position 1.....	13
2.3.3 Stop.....	14
2.3.4 Play/Pause	14
2.3.5 Settings.....	14
2.3.6 USB Icon.....	14
2.3.7 Distance Readout	14
2.3.8 Direction Icon	15
2.4 Settings Menu	15
2.4.1 Back.....	15
2.4.2 Product Registration	15
2.4.3 Screen Brightness.....	16
2.4.4 Firmware Update	16
2.4.5 Joystick Calibration	16
2.4.6 Information.....	16
3. OPERATION	17
3.1 Helipath Quick Action Stand Setup	17
3.1.1 Helipath Setup	17
3.1.2 Power Up.....	17
3.1.3 Product Registration.....	18

3.2 Helipath Test Run.....	18
3.3 Quick Action Test Run.....	21
3.4 Joystick Calibration Procedure.....	23
3.5 Firmware Update	24
APPENDIX A – HPQA ASSEMBLY & HANDLING INSTRUCTIONS	25
UNPACKING	26
ASSEMBLY	26
VISCOMETER MOUNTING.....	26
STORAGE.....	27
CARRYING.....	27
APPENDIX B - FAULT DIAGNOSIS AND TROUBLESHOOTING	28
TECH SUPPORT	30
TROUBLESHOOTING.....	30
APPENDIX C - INTEGRATED HELIPATH QUICK ACTION, HPQA, OPERATION WITH THE DVPLUS	32
APPENDIX D - ONLINE HELP AND ADDITIONAL RESOURCES.....	36
APPENDIX E - WARRANTY REPAIR AND SERVICE	37

1. INTRODUCTION

The AMETEK Brookfield HPQA, Helipath Quick Action Stand, is the most advanced lab stand for all your measurement needs. Building on the legacy Helipath stand, the HPQA is a variable speed motorized lab stand that can be used for both Helipath measurements or as an advanced motorized quick action lab stand.

For viscosity/consistency measurement of gels, pastes, creams, putty, gelatin, and other non-flowing substances, an AMETEK Brookfield Viscometer or Rheometer is mounted on the Helipath Quick Action Lab stand and a T-bar spindle is attached to the viscometer using a special threaded or magnetic coupling. When a Helipath test is initiated, the drive motor slowly lowers or raises the viscometer at a rate of 0.39 mm/s so that the T-bar spindle creates a helical path through the test sample, thus eliminating the problem of “channeling”.

- Compatible with all AMETEK Brookfield viscometers and DVNext Rheometers
- Simple to set up and clean
- Provides a solution for hard-to-measure materials
- Complete with drive motor, 6 T-bar spindles with coupling, case, lab stand rod and base
- The Helipath Quick Action Stand is available with Magnetic Spindle Coupling Option, allowing spindles to be quickly attached and removed, and preventing damage that can occur from frequent spindle changes or multiple users
- Programmed Home and Top positions allow quick one touch stand movements for easy cleaning and preparation for the next test
- Variable speed travel up to 40 mm/s with joystick

HELIPATH VISCOSITY RANGE cP (mPa s)			
	DIAL, DVE, DVPLUS, DV1	DV2T	DV3T/DVNEXT
LV VISCOSITY RANGE	156-3.12M	156 - 9.36M	156 - 9.36M
RV VISCOSITY RANGE	2K - 20M	2K - 100M	2K - 100M
HA VISCOSITY RANGE	4K - 40M	4K - 200M	4K - 200M
HB VISCOSITY RANGE	16K -160M	16K - 800M	16K - 800M

**Maximum range shown is at 0.1 rpm, K= 1 thousand M = 1 million, cP = Centipoise mPas = milliPascal second

In addition to the traditional Helipath test mode, the HPQA Lab stand works as a powerful, variable speed, motorized lab stand for use with standard spindle sets. Traveling at speeds up to 40 mm/s, the variable speed joystick allows customers to immerse spindles quickly and accurately. One touch Home and programmable Park locations allow customers to quickly move the instrument head up and out of the way for spindle cleaning and sample change over.

1.1 Components

Components	Part Number	Quantity
HPQA Head and Upright Rod Assembly w/ 1/4-20 Bolt	N/A	1
Model G Laboratory Stand Base	GV-1201	1
T-Bar Spindles Set of Six (#91 - #96) w/Case	SST or SSTM†	1
Power Cord	Varies	1
Power Supply	HP-2010	1



† “M” in the part number identifies magnetic spindles.

Please check to be sure that you have received all components and that there is no damage. If you are missing any parts, please notify AMETEK Brookfield or your local authorized dealer immediately. Any shipping damage must be reported to the carrier. Please save packaging materials in case the unit needs to be shipped for service.

1.2 Utilities

VAC; Hz Limits: 100 - 240 VAC; 50/60 Hz \pm 5%

Power Supply (AMETEK Brookfield P/N HP-2010): 24VDC 60 Watts, Class II certified plug-in power supply, Overvoltage Category II

	Main supply voltage fluctuations are not to exceed 10% of the nominal supply voltage.
	Must be used with HP-2010 Power Supply. Alternative power sources may cause damage to the instrument.

1.3 Component Diagram

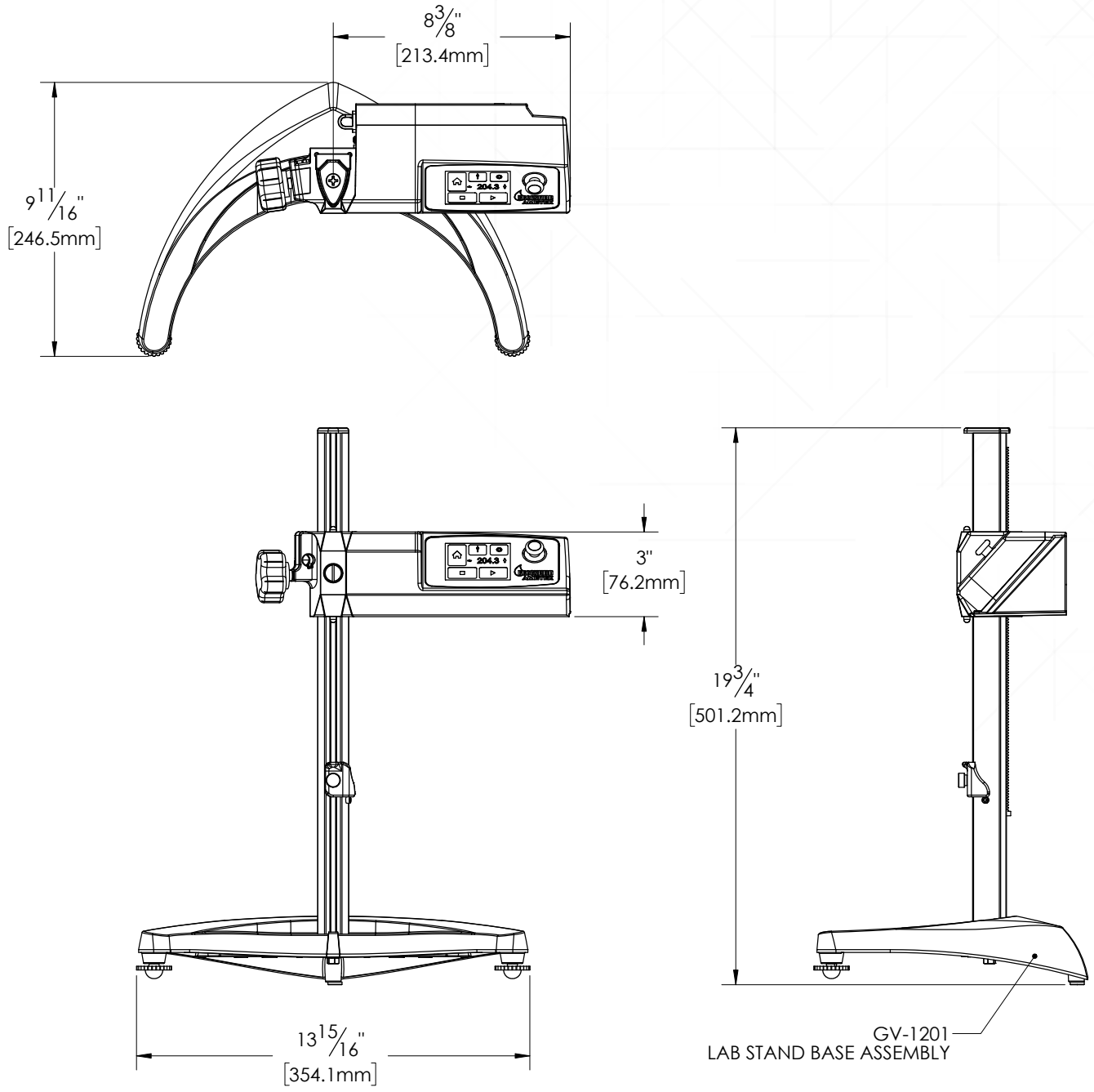

Figure 1-3.1

1.4 Specifications

Speed:	0.1 to 40mm/s
Weight:	10lbs
Operating Environment	0°C to 40°C Temperature Range (32°F to 104°F, 273.15K to 313.15K) 20% - 80% R.H.: non-condensing atmosphere, maximum altitude 2000m (6561 ft.), indoor use only
Ingress Protection Rating:	IP3X
Pollution Classification	Degree 2
Electrical Certification:	Conforms to CE Standards: EN IEC 61326-1:2021: Electrical equipment for measurement, control, and laboratory use - EMC requirements. EN 61010-1:2010+A1:2019: Safety requirements for electrical equipment, for measurement, control, and laboratory use. EN IEC 63000:2018: Technical documentation for the assessment of electrical and electronic products with respect to the Restriction of Hazardous Substances Directive (RoHS 3)

Notice to customer:



This symbol indicates that this product is to be recycled at an appropriate collection center.

Users within the European Union:

Please contact your dealer or the local authorities in charge of waste management on how to dispose of this product properly. All AMETEK Brookfield offices and our network of representatives and dealers can be found on our website: www.brookfieldengineering.com.

Users outside of the European Union:

Please dispose of this product according to your local laws.

We request our customers to save the packaging material and reuse it while shipping for servicing/repairs.

1.5 Installation

1. Assemble the Helipath Quick Action Stand by bolting the extrusion to the base with the provided bolt and washer. (Refer to assembly instructions in Appendix A of Figure 1.5.2)
2. Slide the Viscometer mounting handle into the clamp on the Helipath Quick Action stand until it stops
3. Visually align Viscometer head with the extruded Lab stand rod and secure by tightening molded star knob
4. Make sure that the power switch at the rear of the Helipath Quick Action stand is in the OFF position. Connect the power cord to the power supply provided. Do not use any other power supply or the warranty may be voided. Plug the power supply cable into the Helipath power inlet



The Helipath Quick Action Laboratory stand must be used with the provided power supply. Indoor use only.

The power supply must be earth grounded to maintain compliance with electrical certifications. Verify that all I/O cables and accessories are clear of the top of the stand. A collision can cause damage. If you use a folding USB drive, make sure the cover is folded to clear the stand. See Figure 1.5.1

5. Turn the power switch on rear panel to the ON position
6. Press the  HOME Icon to begin the homing process
The Helipath Quick Action Lab stand will move up automatically during the homing process. Ensure the Viscometer and Lab stand have adequate clearance at all positions. Remove spindles during homing
7. Level your Viscometer or Rheometer using the two leveling feet located at the front of the stand
8. Your Helipath Quick Action Lab Stand is now ready for use



Figure 1.5.1

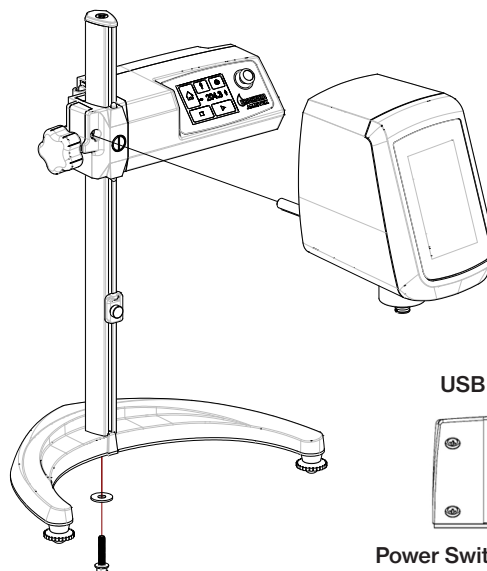

Figure 1.5.2

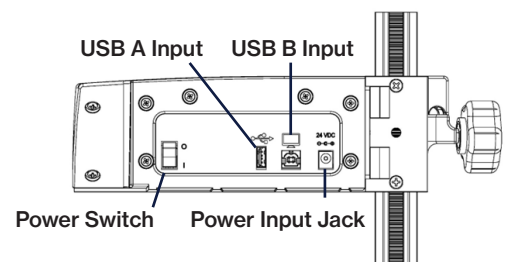



Figure 1.5.3









1.6 Safety Symbols and Precautions

Safety Symbols:





The following explains the safety symbols that may be found in this operating manual.

	Indicates hazardous voltages may be present.
	Refer to the manual for specific warning or caution information to avoid personal injury or damage to the instrument.

Precautions:

	If this unit is used in a manner not specified by the manufacturer, the protection provided by the instrument may be impaired.
	This unit is not intended for use in a potentially hazardous environment.
	In case of emergency, turn off the unit and then disconnect the electrical cord from the wall outlet.
	The user should ensure that the substances placed under test do not release poisonous, toxic, or flammable gases at the temperatures to which they are subjected during the testing.
	The safety of any system incorporating this equipment is the responsibility of the assembler of the system.
	Make sure the unit is on a level surface.
	Keep fingers, long hair, and loose clothing clear of moving parts, to avoid pinching hazards. In the case of entrapment or uncontrollable movement, unplug the HPQA and manually move the moving assembly.
	Once a spindle is installed and the sample container is set up, set the bottom end-stop so a collision cannot occur. A spindle collision can cause damage to the viscometer, spindle, or container.

1.7 Preventative Maintenance and Cleaning

	Make sure that the unit is in a clean, dry working environment (dust-free, moderate temperature, low humidity, etc.).
	Make sure hands are clean when operating the Helipath to prevent build up on the screen or joystick.
	Be sure gear rack assembly is free of debris and any spilled test materials.
	When cleaning, do not apply excessive force, which may result in bending spindles.
	Instrument and Display: Clean with a dry, non-abrasive cloth. Do not use solvents or cleaners. The instrument housing is manufactured from polycarbonate ABS. Clean Instrument housing with damp cloth. Do not apply solvent to the instrument!

2. GETTING STARTED

2.1 Power up

The Helipath Quick Action Laboratory Stand will go through a Power Up sequence when the power switch is turned on. The touch screen will display a Splash screen for 5 seconds. The Splash screen is shown below (Figure 2.1) and includes the model number, the firmware version number, and the serial number.



Figure 2.1

The Splash screen information can also be accessed through the Settings Menu, using the Settings Button. (see Section 2.4)

2.2 Start Up Screen

Upon powering up, the Helipath Quick Action Lab stand will need to perform a Homing operation prior to using the stand. The screen below will be displayed.

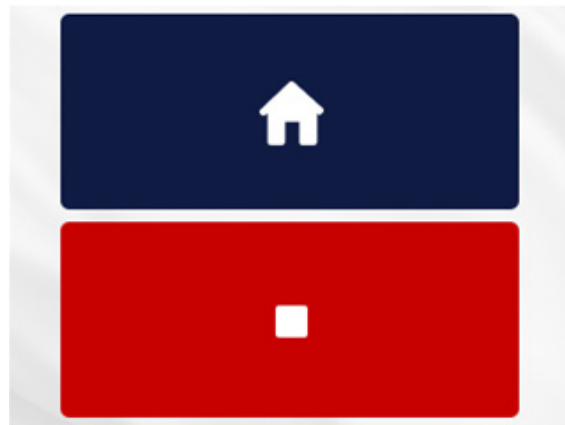

Figure 2.2



The Helipath Quick Action Lab stand will move up automatically during the homing process.

The operator must press the Homing Button (refer section 2.3.1) to initiate the Homing. The operator may stop the Homing process at any point by pressing the Stop Button (section 2.3.3) When complete, the Main Menu will be displayed. An error 106 message prior to the homing process indicates the stand is out of level by more than 7.5 degrees. Level the stand before proceeding.

2.3 Main Menu & Joystick

The Main Menu of the Touch screen and Joystick are the primary control methods for the Helipath Quick Action stand.

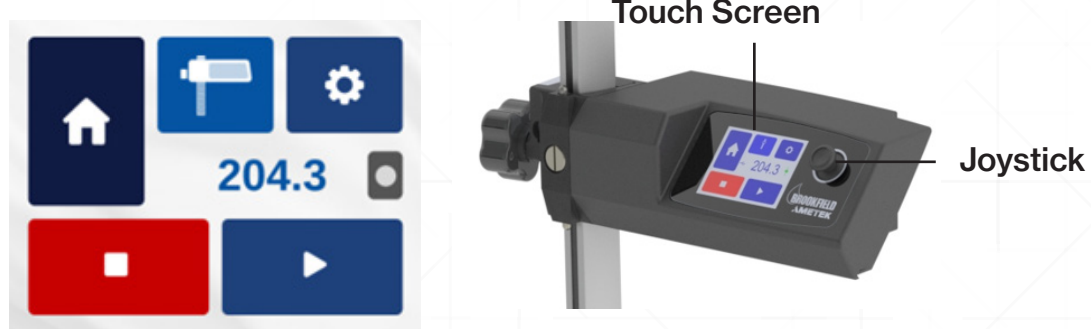

Figure 2.3

2.3.1 Homing



- The Home position is located at the very top of the stand and defines the zero position of the travel of the instrument
- After the initial Homing of the instrument, a quick press of the Home button will cause the head to move automatically back to the Home position
- Pressing and holding the Home button for 3 seconds will force the instrument to re-home
- The button will turn from dark blue to green whenever the HPQA head is at the Home position

2.3.2 Test Position 1



- Test Position 1 (Also referred to as P1) defines the top position of an oscillating Helipath test. A Helipath test will travel between this programmed position down to the mechanical stop location (section 2.3.8) and back
- A quick press of the Test Position 1 button will cause the head to move automatically back to the programmed position
- Pressing and holding the Test Position 1 button for 3 seconds will force the instrument to program the current location of the head as Test Position 1
- The button will turn from blue to green whenever the HPQA head is at the Test Position 1 location
- Pressing the Play Button (section 2.3.4) automatically programs the current position as Test Position 1. This is the quickest way to define the Top Position of a Helipath test

2.3.3 Stop



- The Stop Button will stop the motion of the Helipath Quick Action stand at any time
- Pressing the Stop button will cancel all automated movements including Homing, returning to programmed Test Positions, and Helipath Test operations. These actions will need to be restarted from the beginning

2.3.4 Play/Pause



- The Play/Pause Button controls starts the Helipath oscillating test
- Pressing the Play button programs the current location as the top Test Position 1 and begins the downward motion of a standard Helipath Test
- The Play button will turn into a Pause symbol after the Helipath test is initiated. Pressing the Pause button will pause the Helipath test motion while remembering the Test Position 1 programming location

2.3.5 Settings



- The Settings Button will bring the user to the Settings Menu
- The Settings menu will allow users to adjust the Screen Brightness, Update Firmware, access the registration barcode, and calibrate the joystick

2.3.6 USB Icon



- The USB icon indicates that a USB-B cable is plugged in
- A USB-B cable is used in integrated mode with compatible viscometers

2.3.7 Distance Readout

204.3

- The distance readout indicates the current location relative to home
- The distance is indicated in millimeters

2.3.8 Direction Icon



- The direction icon indicates the current movement direction
- A gray circle indicates no movement
- A green arrow indicates movement in the direction of the arrow

2.4 Settings Menu

The Settings Menu can be accessed from the main menu by pressing the settings icon. The Settings Menu can be seen below and provides control of the screen brightness, firmware updates, product registration, Joystick calibration. It also provides general information including the model number, firmware build, and serial number.

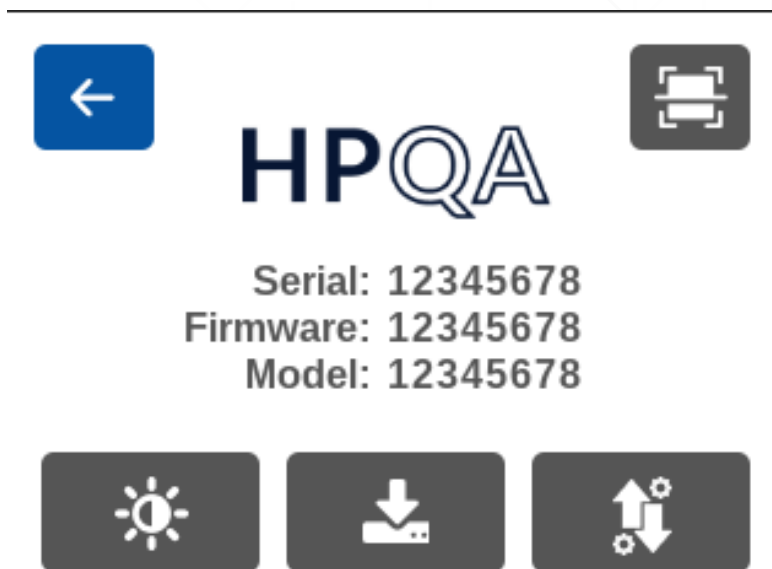

Figure 2.4

2.4.1 Back



The back button will bring the user back to the previous screen

2.4.2 Product Registration



- The product registration button will show a QR code on the screen
- The QR code can be scanned to bring the user to a website to register the product

2.4.3 Screen Brightness



- The screen brightness button leads to a screen to change the screen brightness
- The brightness can be set from 10 to 100 in increments of 10
- The plus button increases brightness, and the minus button decreases brightness

2.4.4 Firmware Update



- The firmware update button leads to a screen to update the firmware
- The current version will be shown on the screen
- **Warning.** Insure that only one firmware download is loaded into the root folder of the USB Flash drive. The HPQA will load the first .img firmware file it locates. Insert a USB drive with a valid firmware version
- Update the firmware by tapping the circular download button on the firmware update screen

2.4.5 Joystick Calibration



- The joystick calibration button leads to a screen to calibrate the joystick
- This is set from the factory. Only perform a calibration if the joystick is not behaving correctly or if directed by customer support
- The play button starts calibration
- Move the joystick and hold it at each position indicated by green
- Calibration is complete when a checkmark popup appears

2.4.6 Unit Information

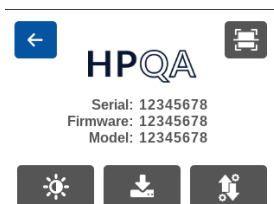

- Unit information is shown on the settings screen
- Serial number, firmware version, and model number are shown

3. OPERATION

3.1 Helipath Quick Action Stand Setup

3.1.1 Helipath Setup

- Assemble the HPQA Laboratory Stand (refer to assembly instructions in Appendix A of this manual)
- Insert the viscometer mounting handle into the lab stand clamp and tighten
Do not tighten the knob without a viscometer installed; damage may occur



3.1.2 Power Up

- Connect the power cord to the provided power supply. Plug the power cord into an A/C outlet and the barrel connector into the rear of the HPQA. Do not provide power to any other port; only the barrel port should supply power



- Route power cables for the both the viscometer/rheometer and the Helipath through the cable management clips located on the back of the Helipath. Ensure all cables are clear of moving parts and have enough slack to allow the full range of travel of the Helipath Quick Action Stand



Power cables

- Turn on the HPQA by using the power switch on the rear of the instrument

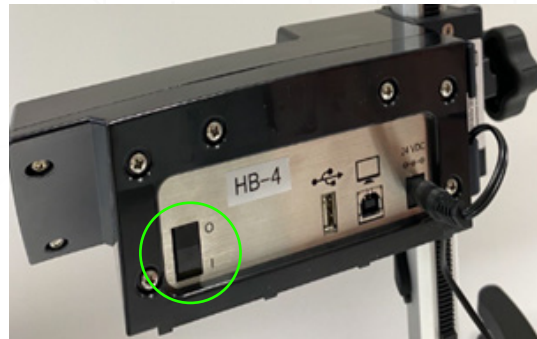

- Perform the Homing procedure as described in section 2.2. Do not AutoZero or run a test on the viscometer while the HPQA is Homing

3.1.3 Product Registration

Press the Settings Icon, then press the Scan Icon to open the QR code to register your product and receive information on how to download the operating instructions.



Ensure faster support by registering your instrument. Scan the QR code or visit:
www.brookfieldengineering.com/contactus/register-product

3.2 Helipath Test Run

1. The Joystick control can be used to lower or raise the Helipath manually



2. Attach the appropriate spindle to your Viscometer/Rheometer and lower the black Lower Mechanical Stop to its lowest position



3. Place your test sample below the spindle and carefully lower the Spindle into the fluid to the desired bottom position (not closer than $\frac{1}{4}$ " to the bottom of the container) for your oscillating Helipath test using the joystick



4. Adjust the black Lower Limit Stop up until it touches the silver button on the bottom of the Helipath stand. Tighten the Lower Stop in place

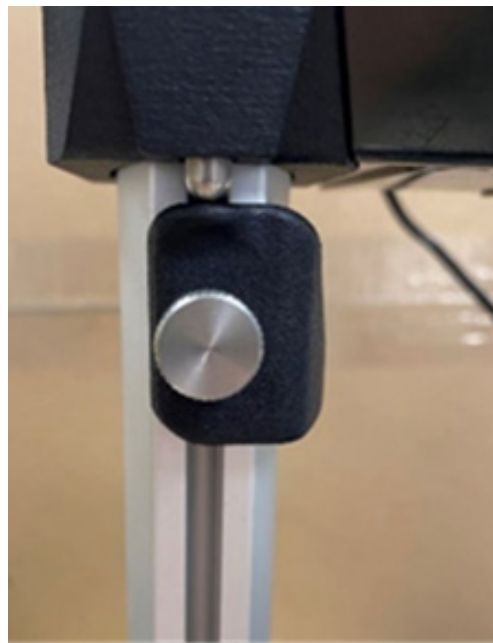

5. Use the Joystick to raise the Helipath head and spindle to the desired starting test position



6. Start the desired test on your Viscometer/Rheometer
7. Press the Play/Pause button  to start the HPQA descent. An Arrow Icon will appear on the right side of the screen confirming the HPQA direction of travel





8. When the HPQA reaches the Lower Limit Stop, the reverse switch will automatically activate and the HPQA will start ascending. The Arrow Icon will change to reflect the new direction of travel



9. When the HPQA reaches the test starting position, it will automatically reverse its direction and descend again

10. To stop the test, press the Stop button 

11. To move the head up you can press the Home button  or Test Position 1 button  to automatically go back to those programmed locations. The P1 button will bring you back to the top position of your last Helipath Test run. You may also use the joystick to manually drive the head up to the desired position for spindle cleaning



3.3 Quick Action Test Run

The Helipath Quick Action laboratory stand can be used as a motorized quick action replacement for any standard AMETEK Brookfield lab stand. Traditional Viscosity test can be run with ease with automated one touch movements.

- Simply push on the HPQA Joystick to move the viscometer/rheometer up or down the Upright Rod to the desired position
 - The further you push the joystick in the direction of desired travel, the faster it will go



- Release the Joystick to stop the movement of the HPQA
- Setup a standard viscosity test following the viscometer manual
 - Attach your desired spindle and configure your test on your DV Viscometer or Rheometer

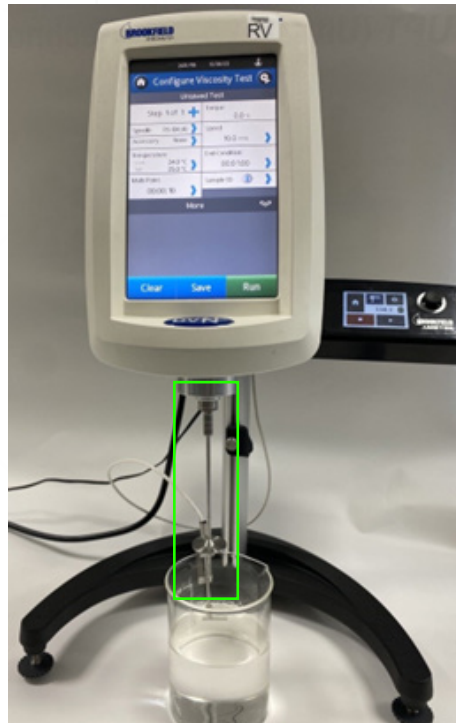

- Use the joystick to lower the spindle to the proper immersion depth



- Begin the test on your instrument by pressing the RUN button on viscometer/rheometer.
- At completion of the test, a single press of the Home button  will automatically raise the head to the Home position for cleaning and sample setup



If lower mechanical stop is preventing your spindles from reaching proper immersion depth, the stop limiting bolt can be removed with a 7/64" hex key wrench. This will allow the lower stop to be moved down and allow additional downward travel. Please be careful to prevent driving spindles into bench top or the bottom of your sample containers.

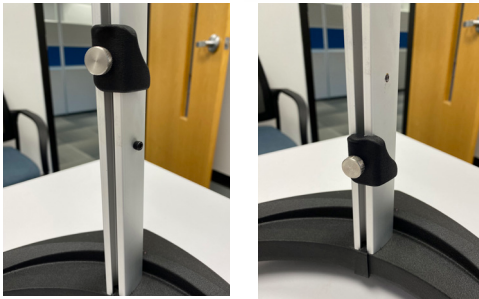

3.4 Joystick Calibration Procedure

1. From the main screen of HPQA, click on Setting icon which navigates to the Settings screen.
2. Click on “Joystick Calibration”  icon, navigates to Joystick Calibration screen

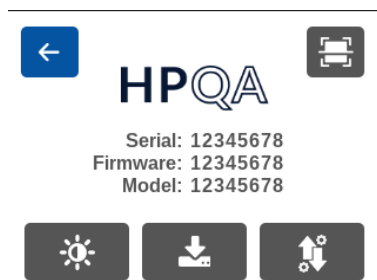

3. Press “Play” button to start the calibration of Joystick



4. Upon clicking the “Play” button, upper directional arrow highlights in the green color, which indicates to move the joystick in upward direction and hold until color changes back to grey and central part of the joystick icon turns green



5. Release the joystick until the downward arrow turns green. Hold the joystick in the downward direction until color changes back to grey and central part of the calibration icon highlights in the green color



Upon successful completion of the Joystick Calibration, pop-up appears with “check” mark along with back arrow button



3.5 Firmware Update

1. Press the Settings Icon, then press the download icon to navigate to firmware upgrade screen
2. It will display the current firmware version
3. Insert the USB with latest firmware into the HPQA USB A slot on the rear panel. USB drive must contain only one firmware file
4. Press download icon in the screen
5. It will download the latest version in the USB
6. If no USB is detected, it will display error message “NO USB detected” with animation
7. After completion of download it will reboot the system and it will display the following colors for firmware update
 - » Blue - Read firmware image file
 - » Green - Erase internal flash image area
 - » Yellow - Write internal flash image area
 - » Orange - Erase external flash image area
 - » Red - Write image partition to external flash
 - » Brown - Erase downloaded image.

APPENDIX A – HPQA ASSEMBLY & HANDLING INSTRUCTIONS

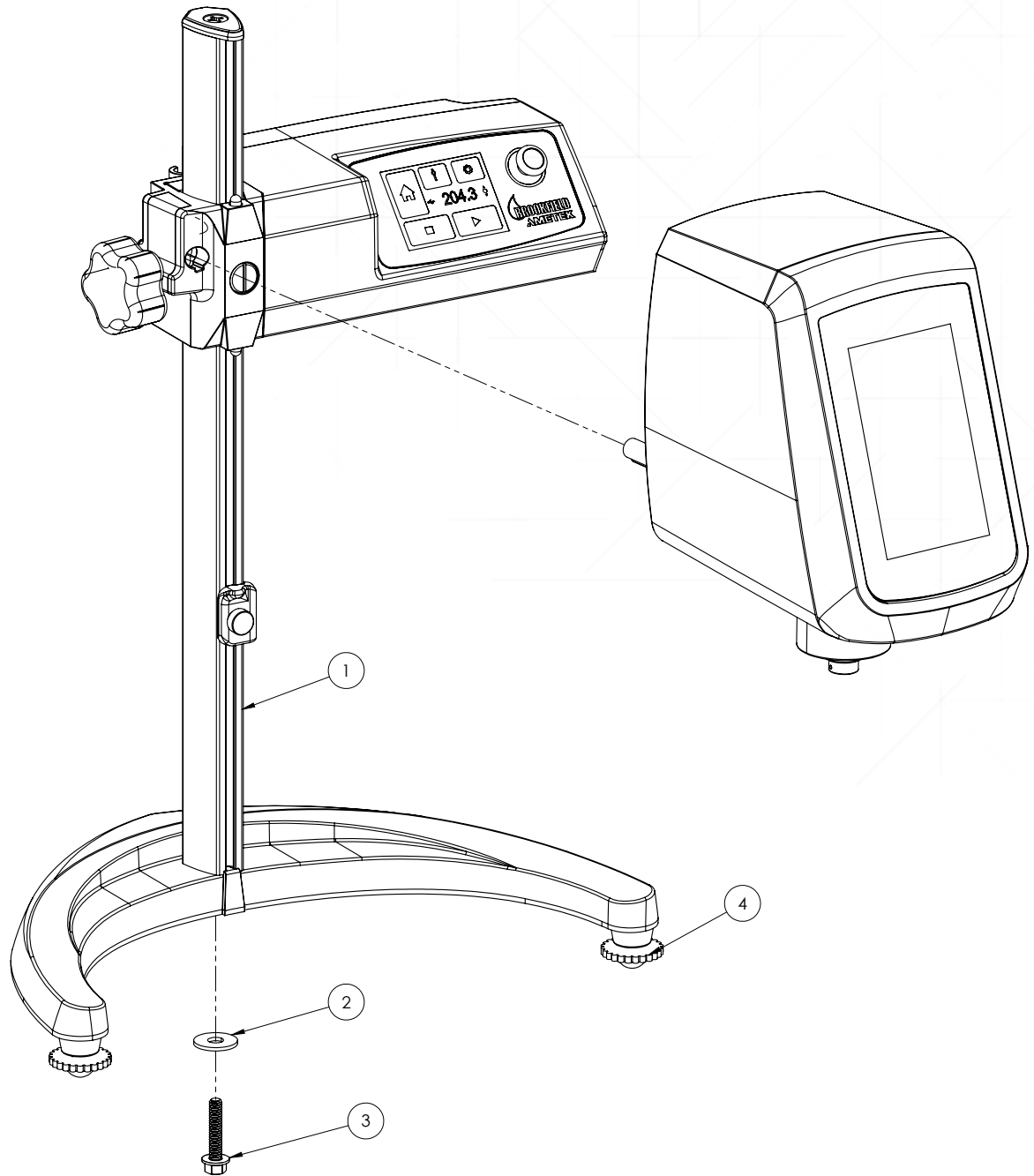

ITEM NO.	PART NO.	DESCRIPTION	QUANTITY
1	GV-1201	BASE, INCLUDES (2) GV-1203 LEVELING SCREWS	1
2	502028071S33B	FLAT WASHER, 5/16 X 7/8 X .071 THICK, STEEL BLACK OXIDE	1
3	50S252040E540	SCREW, 1/4-20 X 1 1/4" LG FLANGED HEX NUT	1
4	GV-1203	GV-1203 LEVELING SCREWS (REPLACEMENT PARTS ONLY)	2

Figure A-1: HPQA Laboratory Stand

UNPACKING

We recommend our customers to save the packaging material and reuse it while shipping for servicing/repairs. Check carefully to see that all the components are received with no concealed damage:

- 1 Base, GV-1201, with 2 Leveling Screws
- 1 Upright Rod with attached HPQA
- Power Supply, HP-2010
- Power Cord, Varies by Region
- T-bar Spindles with case, SST (threaded) or SSTM (magnetic)

ASSEMBLY (REFER TO FIGURES A-1)

- Remove the base assembly from the carton
- Remove the flanged screw from the upright rod
- Prop the Helipath head and extruded rod up on the foam as shown below



- Align the keys on the base with the slots of the extruded upright rod
- While holding the rod and base together, insert the flanged bolt with washer as shown and tighten securely with a 3/8" wrench or socket
- Stand the Helipath Quick Action stand up and place on a level surface

VISCOMETER MOUNTING

- Insert the Viscometer or Rheometer mounting handle into the hole (with the cut-away slot) in the clamp assembly. Slide the handle as far back as it will go and visually align the Viscometer/Rheometer head with the extruded rod
- Tighten clamp with star knob to secure instrument in the Helipath Quick Action Clamp.
Do Not Overtighten!
- Turn on the instrument and follow the instructions for leveling. Use the leveling screws to "fine" adjust the Viscometer level

Note:



If the Digital Viscometer cannot be leveled, verify that your upright rod is properly aligned and fastened to the base.



Do not tighten the clamp knob unless the Viscometer mounting rod is inserted in the clamp assembly. Only install AMETEK Brookfield Viscometers and Rheometers in the HPQA. Overloading or installation of incompatible instruments may cause unwanted movement or tipping.

STORAGE

Store the Helipath Quick Action stand in a dry place between 0 and 40 degrees Celsius

CARRYING

Power off and unplug the HPQA and Instrument before moving. Carry by securely holding the vertical rod between the moving assembly and the base.

APPENDIX B - FAULT DIAGNOSIS AND TROUBLESHOOTING

Error #	Description
0	RTC BATTERY VOLTAGE LOW
1	RTC RESET OCCURRED
2	SUPPLY VOLTAGE LOW
3	EEPROM INIT FAILED
4	RTC INIT FAILED
5	ACCEL INIT FAILED
6	STEPPER MOTOR DRV INIT FAILED
7	TORQUE SENSOR INIT FAILED
8	RTD INIT FAILED
9	INSTRUMENT RESET DUE TO HARD FAULT EXCEPTION
10	INSTRUMENT RESET DUE TO MEMORY FAULT EXCEPTION
11	INSTRUMENT RESET DUE TO BUS FAULT EXCEPTION
12	INSTRUMENT RESET DUE TO USAGE FAULT EXCEPTION
13	INSTRUMENT RESET DUE TO STACK OVER FLOW
14	FILESYSTEM WAS MISSING. REFORMAT FAILED
15	FILESYSTEM WAS MISSING. NEW INSTANCE CREATED
16	FILESYSTEM WAS MISSING. NEW INSTANCE CREATE FAILED
17	CHECKDISK REPORTED FAT CHAIN ERRORS
18	CHECKDISK REPORTED DIRECTORY ERRORS
19	CHECKDISK REPORTED LOST CLUSTER ERRORS
20	CHECKDISK REPORTED FILE SIZE ERRORS
21	TOUCH SCREEN INITIALIZATION FAILED
22	SYS TIME INITIALIZATION FAILED
23	SDRAM INITIALIZATION FAILED
24	RTC TIME INVALID
25	ADC INIT FAILED
26	LCD DRIVER INIT FAILED
27	MOTOR FAULT RESTART UNIT
28	UPPER LIMIT SWITCH HIT UNEXPECTEDLY

29	LOWER LIMIT SWITCH HIT UNEXPECTEDLY
30	LIMIT SWITCH ENGAGED ON STARTUP
31	ACCELEROMETER TEMPERATURE BELOW THRESHOLD
32	ACCELEROMETER TEMPERATURE ABOVE THRESHOLD
33	LOWER LIMIT SWITCH READ ERROR
34	UPPER LIMIT SWITCH READ ERROR
42	MAX HPQA CYCLES REACHED
43	INVALID USB DEVICE INSERTED
47	USB COMMUNICATION LOST DURING TEST
100	LEVEL CALIBRATION NOT VALID
101	SAVE OF LEVEL CALIBRATION DATA FAILED
102	READ OF LEVEL CALIBRATION DATA FAILED
103	READ OF ACCELEROMETER DATA FAILED
104	LEVEL CALIBRATION FAILED. MAX OFFSET EXCEEDED
105	MAX TILT ANGLE OF 7.5 DEGREES EXCEEDED
106	MAX TILT ANGLE OF 7.5 DEGREES EXCEEDED ON STARTUP
200	JOYSTICK CALIBRATION TIMED OUT
201	JOYSTICK CALIBRATION READINGS INVALID
500	FAILED TO GET FX MEDIA AND PATH FROM WINDOWS PATH
501	FAILED TO OPEN FILE
502	FILE SIZE TOO LARGE
503	ERASE OF DOWNLOAD AREA FAILED
504	READ OF DOWNLOAD DATA FAILED
505	READ OF DOWNLOAD DATA FAILED. BYTES READ DID NOT MEET EXPECTED
506	WRITE OF DOWNLOAD DATA FAILED
507	VERIFICATION FAILED
1200	PRODUCT DATA INIT FAILED
1201	PRODUCT DATA WRITE FAILED
1300	PRODUCT SETTING INIT FAILED
1301	PRODUCT SETTING WRITE FAILED

TECH SUPPORT

Information about the unit such as model number, firmware build, and serial number can be found on the main Settings screen. Please access the support information through the Main Menu, using the Settings button.

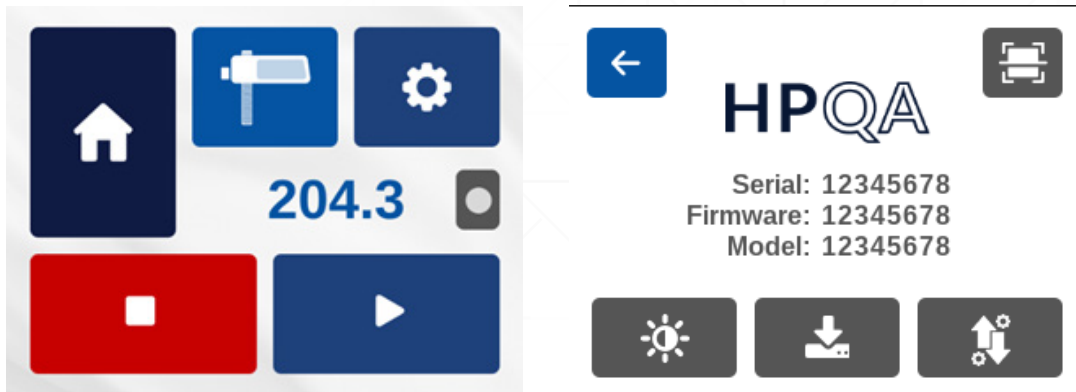

TROUBLESHOOTING

1. Stall Behavior

- If the HPQA stalls (motor trying to turn but no physical motion) the following steps should be taken
 - Press the stop button on the LCD to disable the motor
 - Clear the obstruction that is causing the movement to be interrupted
 - Re-home the instrument by hitting the home button on the LCD

2. Bent Spindle

- If a spindle becomes bent this indicates that the spindle is striking the bottom of the sample container during a test. To prevent this issue the following should be observed
 - When setting the lower position of the test ensure that the stop completely depresses the limit switch (silver button on sled) prior to contacting the bottom of the sample container
 - Ensure the screw on the stop is tight

3. Tip Warning

- If an Error 105 occurs on the screen the instrument has tilted past 7.5 degrees off of vertical. To resolve this issue perform the following
 - Turn off HPQA from power switch on back
 - Clear obstruction that caused the tip condition. Check cabling and the spindle for contact with the bottom of the sample container
 - Once obstructions are clear power HPQA on
 - Re-home the unit

4. False Tip Warning

- If an Error 105 occurs and the instrument is not tilted past 7.5 degree a false detection has occurred. To resolve this issue check the following:
 - Vibration of the instrument is the most likely cause of a false tip detection. Ensure the HPQA is on a stable platform

5. Instrument becomes “stuck” at the lower limit switch

- If the instrument stops during a test and becomes “stuck” at the lower limit switch perform the following
 - Power cycle the unit by turning power off and on from the switch on the back of the HPQA
 - On power-up press the home button

6. Instrument becomes stuck at the upper limit switch

- If the instrument stops at any time and becomes “stuck” at the top limit switch
 - Turn off power to the unit from the switch on the back of the HPQA
 - Remove the power cable from the back of the HPQA
 - Physically push the sled assembly away from the top limit switch. If prior two steps are not completed, you will not be able to move the HPQA head assembly
 - Re-connect the power cable and turn ON the HPQA
 - On power-up press the home button

7. Suspected loss of position

- If the user suspects that the home position is slipping or has moved from the original position perform the following
 - Press the home button on the LCD and allow the unit to perform a new homing operation. This will reset the home position

APPENDIX C – INTEGRATED HELIPATH QUICK ACTION, HPQA, OPERATION WITH THE DVPLUS

INTRODUCTION

The Helipath Quick Action Stand (HPQA) and DVPlus offer users the ability to operate and program the HPQA directly from the DVPlus user interface. This capability offers several operating modes and unique features:

- Choose Integrated Helipath, Quick Action, and Manual Helipath Modes
- Helipath movement and action tied directly to Viscosity test program
- Automated end of test movements and actions
- Stop Helipath movement at end of viscosity test
- Move DVPlus to customer programmed location at completion of test
- Repeatable set up locations for different container sizes
- Standard Operating Procedures can be defined by HPQA location (defined in millimeters) for each container size and sample size
- Record of Helipath test setup and movement with viscosity data

INSTRUMENT SETUP AND FIRMWARE REQUIREMENTS

To program and operate the Helipath Quick Action (HPQA) Stand via the DVPlus user interface, the firmware of both instruments must meet the minimum levels shown below. If your device was purchased prior to this firmware release level, please download the latest firmware from the website locations listed below and update per the instructions in the DVPlus and HPQA manuals as required.

- Check that the Firmware for the DVPlus and HPQA meet minimum requirements:

- DVPlus Firmware version 1.6.1.1 or higher
- HPQA Firmware version 1.1.0.15 or higher

Note: Visit the product pages at www.brookfieldengineering.com to find the latest firmware downloads and instructions.

- After the standard instrument setup instructions per the HPQA manual, connect the DVPlus to the HPQA with the supplied 18” USB A-B patch cable (Part Number HP-2011)
 - **Connect USB A side to DVPlus and USB B side to HPQA back panels.**
- Ensure the USB connection symbol is displayed at the top of the DVPlus screen as displayed in Figure Appendix C-1
- If not already Homed, press the large Home button when the HPQA powers on to establish the Home position.
- You are now ready to use the HPQA in Integrated modes.

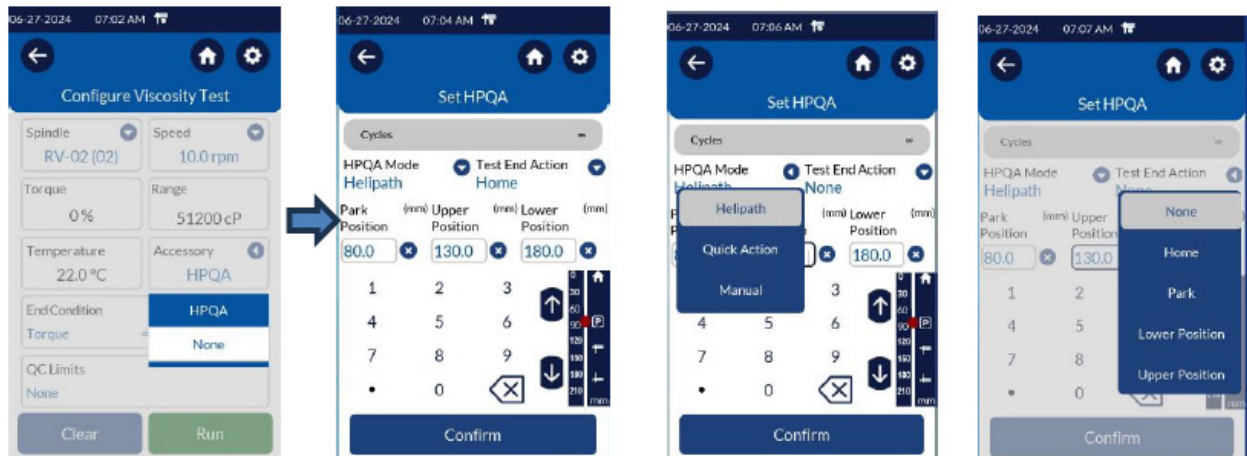

Figure Appendix C-1

INTEGRATED HELIPATH TEST OPERATION

Integrated Helipath Testing allows users to automate and coordinate the action of the HPQA stand with the programmed viscosity test on your DVPlus. This will allow more repeatable test setups, visual indicators when testing is complete, and confirmation that the test utilized the HPQA during testing. The default travel speed during a Helipath test is 0.39 mm/s. To set up and run an integrated Helipath test, follow the steps below.

- Once you've entered the 'Configure Viscosity Test' Screen, click on the Accessory drop down menu and select 'HPQA'. This will automatically take you to the 'Set HPQA' settings screen.



- In the 'Set HPQA' screen, there are a few options to configure your test.
 - HPQA Mode: Choose between Helipath, Quick Action, and Manual test modes. For this instruction, choose Helipath.
 - Test End Action: Allows user to choose what the motorized HPQA stand does at the completion of the viscosity test.
 - None: The DVPlus head and spindle will remain at the location it was when the test ended.
 - Home: Move to the Home position at the top of the stand.
 - Park: Move to the 'Park Position' as defined in the test setup. Park is typically a location above the sample that allows users to see the test is complete and the spindle is out of the fluid, ready to be cleaned.
 - Upper Position: This location is the Top Test position in the fluid. This defines where the Helical path motion will begin, moving from the top to bottom test positions.
 - Lower Position: This defines the height at which the HPQA stand will stop moving down and begin moving back up. (Can't exceed lower travel limit of 215mm in Helipath Test mode).
 - Cycles: Displays how many Helipath cycles will occur if the 'End Condition' for the Viscosity Test is set up to end on Helipath cycles. One cycle is defined as moving from the Upper position down to the Lower position and then traveling back to the starting Upper position. Users can choose cycles in 0.5 increments. A Half cycle would allow the user to travel from the Upper to Lower position and then end the test. If 'cycles' is not chosen as an End Condition, the set number will be infinity and the Helipath motion will run until commanded to stop by an alternate End Condition or manually stopped.
- After selecting 'Helipath' from the HPQA Mode drop down, select what action you'd like to happen at the completion of your test from the 'Test End Action' drop down.
- To set your Park, Upper Position, and Lower Positions:

- It is recommended you place a container with your typical sample volume and container with the correct T-Bar spindle under the stand to help determine the appropriate test positions.
- Touch the number entry box of the position you'd like to set.
- You may type in the desired location (defined in millimeters down from the top Home position), drive the stand to the desired location with the Up/Down arrows on the screen, or use the Joystick on the HPQA stand.
- Once all positions have been programmed, hit the 'Confirm' button to go back to the Configure Viscosity Test screen.
- Configure the remainder of your Viscosity Test and you are now ready to run your test!
 - The Helipath configuration will remain as programmed per the last test for repeat testing on the DVPlus.

INTEGRATED QUICK ACTION OPERATION

Integrated Quick Action operation allows users to automate and coordinate the action of the HPQA stand with the programmed viscosity test on your DVPlus. This is useful for customers that want to automate the movements of the HPQA stand while running standard 'non-Helipath' tests. To set up and run the HPQA with Integrate Quick Action operation, follow the steps below.

- Once you've entered the 'Configure Viscosity Test' Screen, click on the Accessory drop down menu and select 'HPQA'. This will automatically take you to the 'Set HPQA' settings screen.

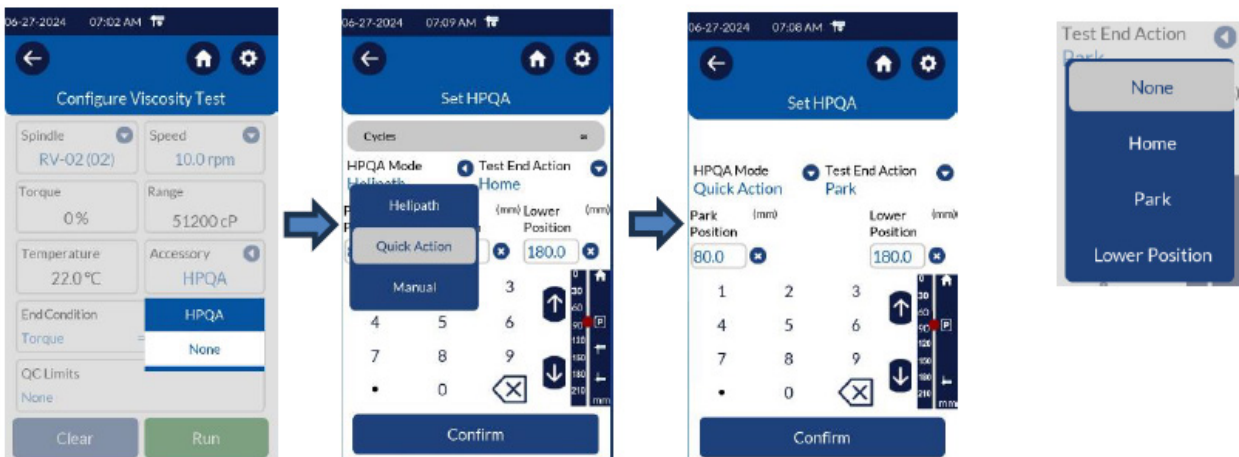

- In the 'Set HPQA' screen, there are a few options to configure your test.
 - HPQA Mode: Choose Quick Action.
 - Test End Action: Allows user to choose what the motorized HPQA stand does at the completion of the viscosity test.
 - None: The DVPlus head and spindle will remain at the location it was when the test ended.
 - Home: Move to the Home position at the top of the stand.
 - Park: Move to the 'Park Position' as defined in the test setup. Park is typically a location above the sample that allows users to see the test is complete and the spindle is out of the fluid, ready to be cleaned.

- Lower Position: In 'Quick Action' mode, the Lower Position is defined as the depth you'd like to immerse the spindle to for running the Viscosity test.
- After selecting 'Quick Action' from the HPQA Mode drop down, select what action you'd like to happen at the completion of your test from the 'Test End Action' drop down.
- To set your Park and Lower Positions:
 - It is recommended you place a container with your typical sample volume and container with the correct spindle under the stand to help determine the appropriate Test positions.
 - Touch the number entry box of the position you'd like to set.
 - You may type in the desired location (defined in millimeters down from the top Home position), drive the stand to the desired location with the Up/Down arrows on the screen, or use the Joystick on the HPQA stand.
- Once all positions have been programmed, hit the 'Confirm' button to go back to the Configure Viscosity Test screen.
- Configure the remainder of your Viscosity Test and you are now ready to run your test!
 - The Quick Action configuration will remain as programmed per the last test for repeat testing on the DVPlus.

STANDALONE/MANUAL HELIPATH TEST OPERATION

If you'd prefer to continue setting up your HPQA separate from your DVPlus Viscosity Test configuration, you can select 'Manual' under the HPQA Mode drop down as shown below. This will allow you to operate the devices separately and is known as 'Standalone or Manual' mode. Refer to your HPQA and DVPlus manuals for the independent set up and operation of each

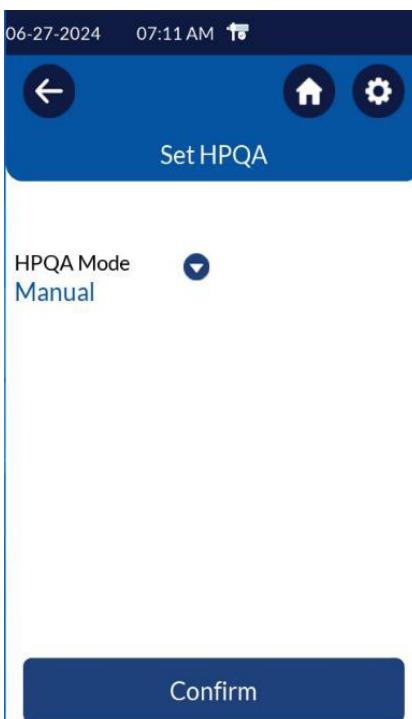

APPENDIX D - ONLINE HELP AND ADDITIONAL RESOURCES

www.brookfieldengineering.com

The AMETEK Brookfield website is a good resource for additional information and self-help whenever you need it. Our website offers a selection of “how-to” videos, application notes, conversion tables, instructional manuals, material safety data sheets, calibration templates, and other technical resources.

www.youtube.com/user/brookfieldEng

AMETEK Brookfield has its own YouTube channel. Videos posted to our website can be found here as well as other “in-house” videos made by our own technical sales group.

More Solutions to Sticky Problems

Learn more about viscosity and rheology with our most popular publication. This informative booklet will provide you with measurement techniques, advice, and much more. It’s a must-have for any AMETEK Brookfield Viscometer or Rheometer operator. “More Solutions to Sticky Problems” is available as a downloadable PDF on the AMETEK Brookfield website by following this path: www.brookfieldengineering.com/downloads/technical-documents.

AMETEK Brookfield University Training Courses

Whether it is instrument-specific courses, training to help you better prepare for auditing concerns, or just a better understanding of your methods, who better to learn from than the worldwide leaders of viscosity measuring equipment? Visit store.brookfieldengineering.com/us-training-schedule/ to learn more about training.

APPENDIX E - WARRANTY REPAIR AND SERVICE

AMETEK Brookfield Viscometers and Accessories are guaranteed for one year from the date of purchase against defects in materials and workmanship. They are certified against primary viscosity standards traceable to the National Institute of Standards and Technology (NIST). The Viscometer must be returned to AMETEK Brookfield or to the authorized dealer from whom it was purchased for a warranty evaluation.

Transportation is at the purchaser's expense. The Viscometer should be shipped in its carrying case together with all spindles originally provided with the instrument. If returning to AMETEK Brookfield, please contact us for a return authorization number prior to shipping.

Many AMETEK Brookfield units are supplied from the factory with a Calibration Seal. The warranty stated above will be voided if the Calibration Seal has been damaged. Only AMETEK Brookfield or our authorized servicing dealers may break the Calibration Seal for purposes of instrument repair or recalibration.

HEADQUARTERS	
AMETEK Brookfield 11 Commerce Blvd. Middleboro, MA 02346 USA 1-508-946-6200 or 1-800-628-8139	
Arizona, USA AMETEK Brookfield 3375 N. Delaware St. Chandler, AZ 85225 USA 1-602-470-1414 or 1-800-528-7411	United Kingdom AMETEK GB LTD T/A Brookfield AMETEK Brookfield Technical Centre 1 Stadium Way Harlow, Essex, CM19 5GX UK Tel: +44 (0) 1279-451774
Africa AMETEK Brookfield Africa Unit 3, Ilangabi House 11 Williams Road, Westville, KwaZulu-Natal 3630 South Africa Tel: +0027 78 860 4325	China AMETEK Trading (Shanghai) Co., Ltd. 4th Floor, Building 4 No. 155 Jiuting Puhui Road Songjiang District, Shanghai (201615) China Shanghai Tel: 86-21-3763 2111 Ext. 8893 Guangzhou Tel: 86-20-8363 4768 Ext. 132 Beijing Tel: 86-10-8526 2111 Ext. 39
France AMETEK SAS BU Brookfield Rond point de l'Épine des Champs Buroplus Batiment D, 78990 Élancour France Tel: +33 01 30 68 89 00	Germany AMETEK GmbH / B.U. AMETEK Brookfield Oberweyerer Str. 21 65589 Hadamar-Steinbach Germany Tel.:+49 06433-9145-4900 Service:+49 06433-9145-4901

India

AMETEK Instruments India Pvt. Ltd.
Bhoruka Tech Park 3rd & 4th Floor, Hoody Village,
ITPL Main Rd, Mahadevapura, Bengaluru,
Karnataka 560048 India
Tel: (91) 11/6618-0800

Thailand

AMETEK (Thailand) Co., Ltd.
Room no. B4.1.1 – B4.1.3 Floor 1st,
SUMMER Lasalle 846/11, La Salle Rd.,
Bangna Tai, Bang Na, Bangkok 10260 Thailand
Tel : +66(0)83 820 5872

WEBSITES

www.brookfieldengineering.com
www.brookfieldengineering.cn
www.brookfieldengineering.de
www.brookfieldengineering.fr
www.brookfieldengineering.in
www.brookfieldengineering.uk

ESTORES

store.brookfieldengineering.com
store.brookfieldengineering.asia
store.brookfieldengineering.eu
store.brookfieldengineering.com.au
store.brookfieldengineering.in
store.brookfieldengineering.uk