



JEROME® 451
MERCURY FIXED POINT MONITOR
OPERATION MANUAL

Manual P/N 700-0096 Revision 1.0
September 2022

Refer to the “431-X Operation Manual”
(P/N 700-0046) for specifics on the 431-X.

www.brookfieldengineering.com

Email:

Sales – sales.jerome@ametek.com

International – international.jerome@ametek.com

Customer Service – customerservice.jerome@ametek.com

JEROME[®] 451 MERCURY FIXED POINT MONITOR Operation Manual

PROPRIETARY RIGHTS NOTICE

This manual contains valuable information and material developed by AMETEK Brookfield for use with the Jerome[®] 451 Mercury Fixed Point Monitoring System. No part of this manual may be reproduced or transmitted in any form or by any means, electronic, mechanical, or otherwise. This includes photocopying and recording or in connection with any information storage or retrieval system without the express written permission of AMETEK Brookfield.

ALL RIGHTS RESERVED



© Copyright 2021 AMETEK Brookfield

Customer Service 800-528-7411 or 602-470-1414
700-0096 Rev. 1.0

Page 2 of 69

Table of Contents

1	INTRODUCTION TO THE JEROME 451	5
2	WARNINGS (READ THIS BEFORE USING THE 451).....	6
3	431-X.....	6
4	SPECIFICATIONS	7
5	STANDARD EQUIPMENT	8
6	OPTIONAL EQUIPMENT	9
7	451 INSTALLATION	10
	7.1 Mounting	10
	POWER CONNECTION.....	10
	7.2 Wind Gauge	11
	7.3 Outdoor/External Antenna Setup.....	12
8	BASE STATION	14
	8.1 Base Station Setup	14
9	451 USER INTERFACE	18
	9.1 Status Items	18
	9.2 Selecting Menu Items.....	18
	9.3 Editing Parameters.....	18
	9.4 Menu Tree.....	19
10	OPTIONAL FUNCTIONAL TEST OF 451/431-X.....	22
	10.1 Test Procedure.....	22
11	JEROME MONITOR SOFTWARE (JMS) INSTALLATION.....	23
	11.1 USB Serial Port.....	24
12	LAUNCHING JMS.....	26
13	JMS SETUP	26
	13.1 First Time Setup.....	27
	13.2 Settings - System Options.....	28
	13.3 Settings - Data Options	30
	13.4 Settings - Email Options.....	31
	13.5 Settings - Notifications Options	32
	13.6 Repeater Setup.....	35
14	JMS OVERVIEW	37
	14.1 Graph Tab.....	39
	14.2 Site View Tab.....	40
	14.3 Data Tab	41
	14.4 Instrument Details Tab	42
	14.5 Reporting Tab	46
	14.6 System Tab.....	49
	14.7 Troubleshooting	51
	14.8 Fresnel Zone.....	52

15	FLOW PUMP KIT	53
16	4-20 MILLIAMP AND SIGNAL RELAY CONNECTIONS	55
16.1	4-20 mA	55
16.2	Signal Relay	57
17	POTENTIAL INTERFERENCES	58
18	MERCURY MONITORING	60
19	MAINTENANCE	61
20	APPENDIX A: RADIO REPEATER SETUP	62
20.1	Example Nano Radio Network	64
20.2	Example Spectra Radio Network (Legacy)	66
21	WARRANTY	68



1 INTRODUCTION TO THE JEROME 451

The Jerome 451 is a non-portable mercury gas monitor designed for perimeter and other outdoor locations. The 451 utilizes a removable 431-X to monitor gas concentrations. The 451 is protected in an insulated all-weather (except flooding) enclosure; it is AC powered and has built-in heat and air-conditioning for increased 431-X accuracy. The 451 can be remotely polled for up-to-date readings or left unattended to log readings for up to a year. A PC that is equipped with “Jerome Monitor Software” (JMS) and a radio modem serves as a Base Station and downloads readings from one or multiple 451’s; the software graphs and reports the data. The 451 is set up at the unit through a menu driven interface and the software can remotely configure the sample and sensor regeneration intervals. The entire system is designed to help monitor mercury levels and meet compliance requirements.



This manual contains details that will optimize the results and the life of your Jerome 451. Read and refer to the manual for complete details on operation, maintenance, and troubleshooting.

The Jerome 451 is easy to operate and ready for use upon receipt from the factory.

- Remove the instrument from the packing material.

 **Retain all packaging materials for any future shipment of the instrument. If the instrument is returned to AMETEK Brookfield for any reason, it must be placed in the original packaging materials that have been tested and proven to be effective protection during shipment.** 

- Call Customer Service for Return Material Authorization (RMA) information prior to returning a unit.
- For all shipments, boxes and packing materials are available from AMETEK Brookfield.
- Pack the Jerome instrument only in a Jerome shipping container.

 **AMETEK Brookfield WILL NOT BE RESPONSIBLE FOR SHIPPING DAMAGE. IF YOU RETURN THE INSTRUMENT IMPROPERLY PACKAGED OR SHIPPED, YOU SHOULD INSURE IT FOR FULL VALUE.** 

- Check for any damage and confirm receipt of all parts on your packing list. Contact Customer Service via phone or through e-mail at customerservice.jerome@ametek.com if you have any questions.

2 WARNINGS (READ THIS BEFORE USING THE 451)



- THE 451 IS **NOT** DESIGNED TO OPERATE IN HAZARDOUS LOCATIONS.
- THE 451 IS **NOT** DESIGNED FOR HEALTH AND SAFETY MONITORING.



- Read the “431-X Operation Manual” (P/N 700-0046) for specifics on the 431-X.
- Sample intervals under 30 minutes will result in a 431-X sensor life of less than 1 year.
- Follow local and national codes when installing the 451.
- It is recommended to use a ground fault circuit interrupter (GFCI) on the AC power circuit for safety in an outdoor environment.
- Do not allow rain to get inside the enclosure.

3 431-X

- In the 451, the 431-X used has been modified to allow remote control of the keypad. A DB9 connector on the back panel allows the 451 to control the 431-X.
- If the 431-X sample button is pressed, the reading is logged by the 451.
Do not use any other 431-X button.
- For maintenance and calibration, the 431-X is easily removed from the 451. An additional 431-X (P/N X431-0151/-0152) can be purchased to keep the 451 operating when you send in a 431-X for calibration.
- To remove the 431-X:
 - Disconnect the AC power for safety. If the 451 is left on, the “431 System Error” occurs on the 451 when a sample is attempted. To clear the error, reset AC power or wait for the 431-X to stop sampling and select the 451’s SYSTEM / RESET menu item.
 - Loosen the 431-X nozzle and pull the elbow fitting out.
 - Disconnect the power and data cables from the 431-X.
 - Use a quick tug to remove the 431-X from the 451.
 - Reverse the procedure to reinstall the 431-X.
- When replacing the 431-X, the clips that hold the 431-X in the 451 may need adjustment. Loosen the three (3) screws for one of the clips and adjust it, so the 431-X snaps in place. If necessary, adjust the second clip as well.
- When the 431-X is calibrated and installed back into the 451, a new VACUSHIELD filter (P/N 800-0065) must be installed in the 451.
- The serial number of the new 431-X must be entered into the 451 using the SYSTEM / ID / 431 SN menu selection at the 451.
- The 431-X’s battery pack is internally disconnected to lower heat generation in the 451. To use the 431-X outside of the 451, re-connect the battery pack and connect

the 431-X to AC power to charge the battery pack; see the Maintenance Section of the 431-X manual.

4 SPECIFICATIONS

The heart of the 451 is a Jerome 431-X instrument; refer to the “431-X Operation Manual” (P/N 700-0046) for specifics on the 431-X. The accuracy and repeatability specifications of the 451 are relaxed to take into account the continuous use of the 431-X sensor.

451 Specifications

Detectable range	0.003-0.999 mg/m ³ Hg
Resolution	0.001 mg/m ³ Hg
Repeatability	8% relative standard deviation at 0.100 mg/m ³
Accuracy	± 8% at 0.100 mg/m ³
Estimated sensor life	6 months at 30-minute sample interval and 48-hour regeneration interval. 3 months at 15-minute sample interval and 24-hour regeneration interval. The interval could be extended in ideal operating conditions.
Flow rate	750cc/min (0.75 liters/min)
User interface	8 digit alphanumeric LCD. Menu driven status and configuration.
Sample interval	1, 2, 5, 10, 15, 30 minutes, 1 and 2 hours
Regeneration interval	6, 12, 24, and 48 hours
Logging capacity	50,000 readings
Power requirements	100-120 VAC, 50/60 Hz, 7 Amps or 210-240 VAC, 50/60Hz, 4 Amps
Control board fuse	Fast Acting IEC 1.6A 250V, 5mm x 20mm
Operating environment	-40° to +55°C (-40°F to +131°F), non-explosive, 0 to 100% relative humidity
Case construction	Polyester with insulation to reduce heat transfer Weatherproof except flooding

Heat and air conditioning	Resistive heating and thermoelectric cooling are used to maintain the temperature between 20°C and 30°C. Temperature may reach 40°C when outside temperature reaches 55°C.
Dimensions	67 cm wide x 64 cm tall x 23 cm deep 26" W x 26" H x 9" D
Weight	24 kg (52 pounds)
Warranty	1 year, factory parts and labor except for 431-X sensor. See WARRANTY section for sensor warranty details.

Spectra Radio-Modem Specifications

Frequency	2.4 GHz (2400 MHz)
Serial Interface	RS-232
Power Requirement	10-30 VDC, 450 mA
Operating Temperature	-40 to 75°C
Range	Up to 6.4km (4 mile) "line of sight" Longer distances may be obtainable through use of a high gain antenna or by using the Radio Repeater.

5 STANDARD EQUIPMENT

- 451 (P/N X451) with door key
- 451 Accessory Kit (P/N Y990-0194)
- 451 Fixed Point Mercury Monitor Operation Manual (P/N 700-0093)
- Base Station Radio Modem Kit (P/N Y990-0279 Nano or P/N Y990-0199 Obsolete Spectra)
- Jerome Monitor Software (JMS) (P/N 710-0040)
- 431-X Mercury Analyzer Operation Manual (P/N 700-0037)

6 OPTIONAL EQUIPMENT

Ammonia Filter Kit (P/N Y990-0202)
Chlorine Filter Kit (P/N Y990-0200)
Wind Gauge (Anemometer) (P/N 980-0010)
451 Wind Gauge Cable (P/N 200-0137)
Flow Pump Kit (P/N Y990-0195)
Radio Repeater Kit (P/N Y990-0278 Nano or P/N Y990-0203 Obsolete Spectra)
Vacushield filter (P/N 800-0065)
451 Enclosure Access Hole Grommet (P/N 350-0128)
Extra 431-X Mercury Analyzer (P/N X431-0151 or X431-0152)
Grounding Strap (for outdoor antennas) (P/N 200-0155)

AMETEK Brookfield has the standard antenna parts below that can be ordered separately. These parts may be installed at the base station, at the 451, or both. Using the shortest possible cables is recommended to minimize potential signal loss. For best results, use a cable that has less than 11dB/100ft signal loss.

The Nano radios have an RP-SMA-Jack connector; a coaxial adapter (P/N 200-0270) is used to convert the radio's RP-SMA-Jack to a RP-TNC-Jack. The legacy Spectra radios have a RP-TNC-Jack connector. The external antennas and lightning arrestors have N-Female connectors.

Radio Modem to Lightning Arrestor Cables

P/N 200-0178 - Cable, RP-TNC-Plug (Radio) to N-Male connector, 5 ft, 2400 MHz
P/N 200-0177 - Cable, RP-TNC-Plug (Radio) to N-Male connector, 50 ft, 2400 MHz

Lightning Arrestors - P/N 200-0181 - Lightning Arrestor (2400 MHz)

Lightning Arrestor to Antenna Cables

P/N 200-0180 - Cable, N-Male to N-Male connector, 5 foot
P/N 200-0179 - Cable, N-Male to N-Male connector, 20 foot

Antennas

P/N 200-0175 - Std. Phantom Antenna, 2400 MHz (Standard on 451)
P/N 200-0173 - High Gain Outdoor Antenna, 2400 MHz, 8dB
P/N 200-0174 - Outdoor Directional Antenna, 2400 MHz

Antenna Mounting Brackets

P/N 300-0489 - Antenna Mounting Bracket, Pole Mount

P/N 300-0490 - Antenna Mounting Bracket, Right Angle Mount to Wall

P/N 300-0491 - Antenna Mounting Bracket, Straight Mount to Horizontal Surface

Call Customer Service for a part that is not listed.

7 451 INSTALLATION

7.1 Mounting

- Because of the weight of the 451, two people may be required for installation.
- Wall Mounting:
Obtain the appropriate anchors from a hardware store for the installation wall type. Drill one of the upper mounting holes into the wall. Hold the 451 to the wall and mark the second upper hole. Drill the second mounting hole into the wall. Temporarily mount the 451 to the wall and mark the lower two holes. Remove the 451 and drill the lower two mounting holes into the wall. Permanently mount the 451 using all four mounting holes.

Power Connection

POWER CONNECTION NOTES:

- When a generator is used to power the 451, a high-quality line conditioner or voltage regulator is required to ensure a pure sine wave and regulated voltage is applied to the instrument. The gold film sensor may be damaged by voltage that varies in amplitude or by surges, spikes, and/or noise on the power line.
- Follow appropriate local and national codes when installing the 451.
- It is recommended to use a ground fault circuit interrupter (GFCI) on the 115V or 220V AC power circuit for safety in an outdoor environment.
- For fixed-point installations where an FTM (P/N Z2600 0930 or Z2600 0918) is going to be used to verify the operation and compliance of the system, the installation of a weatherproof electrical receptacle near the monitoring system is recommended.



The 451-power voltage is not switch-able in the field. The 451 is factory configured to operate at either 115VAC or 230VAC. The switch on the main circuit board indicates the proper voltage and cannot be changed by the user.



POWER CONNECTION PROCEDURE:

1. Ensure the facility circuit breaker for the power line is open.
2. Connect the two power lines and the safety ground as shown.
3. Close the circuit breaker and the 451 is powered.
 - At power UP, the display flashes in order:
 - AMETEK,
 - MONITOR,
 - VX.XX, where X.XX is the version number of the 451's operating program, and
 - X.XXXmg/m³, where X.XXX is the detected concentration of the monitored gas.

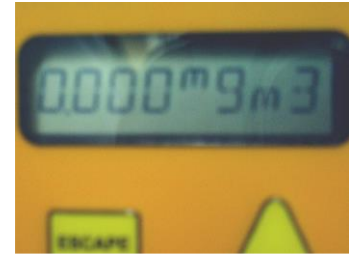

7.2 Wind Gauge

The optional Wind Gauge can be utilized to track wind speed and direction at sites where a weather station or similar system is not available.

INSTALLATION:

- Confirm that the SYSTEM / WIND / ENABLE menu item is set to YES.
- Run the "Wind Gauge Cable" into the hole at the bottom of the 451 and seal the cable entry with the "Grommet" (P/N 350-0128). If desired, cut the excess cable and install a new modular jack; ensure that the new jack is put on in the same direction.
- Connect the "Wind Gauge Cable" to the "451 Control Circuit Board" using the "451 Wind Gauge Cable" (P/N 200-0137).
- Install the Davis anemometer according to the Davis installation manual. When attaching the wind vane, use the 451's "WIND DIR" status item to view the current directional reading. Refer to **§9.1 Status Items** to view status items.

SETUP:

- Using a magnetic compass, select a fixed direction (such as North).
- Turn the directional potentiometer at the top of the Davis anemometer until the display inside the 451 reads the selected fixed direction (e.g., North).
- Carefully install the directional vane on top of the anemometer and secure by tightening the Allen screw.

7.3 Outdoor/External Antenna Setup

If you have purchased the optional outdoor/external antenna for the 451, the standard Phantom antenna mounted in the top of the 451 is unscrewed and replaced with a lightning arrestor installed inside of the 451 enclosure.

1. Connect an appropriate cable from the lightning arrestor to the outdoor antenna. Refer to **§6 OPTIONAL EQUIPMENT** for information on the different cables available. See the diagram below for an example setup.

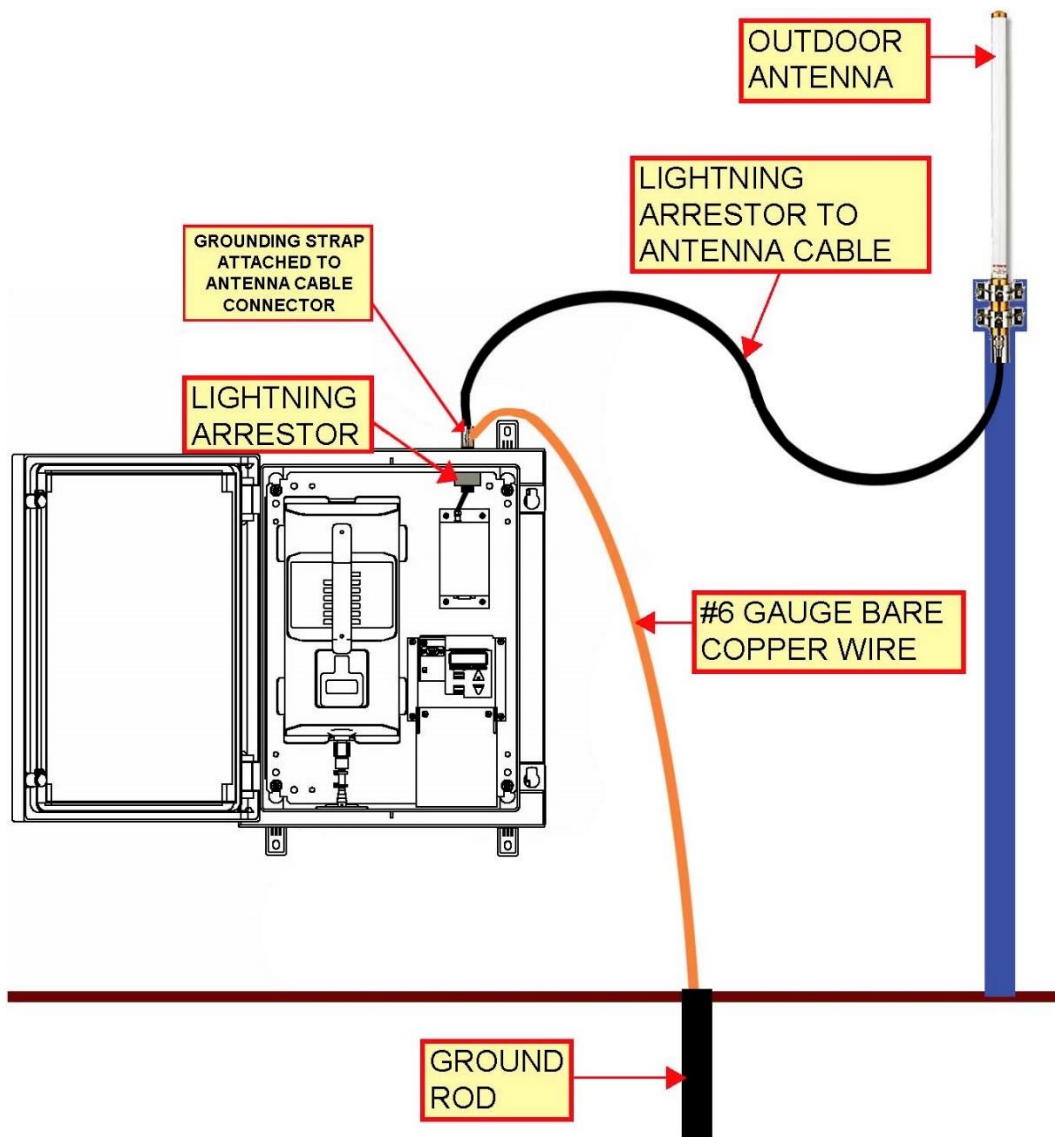

2. The lightning arrester must be grounded to provide protection. Attach the grounding strap to the connector of the cable from the lightning arrester to the antenna. This is just above the lightning arrester, on the outside of the 451 enclosures, as shown below. Use the Grounding Strap to ground the system to a metal water pipe running into the ground, grounding spike, or other appropriate means using #6-gauge bare copper wire. (Follow national/local codes). For additional protection, install a lightning rod as well.

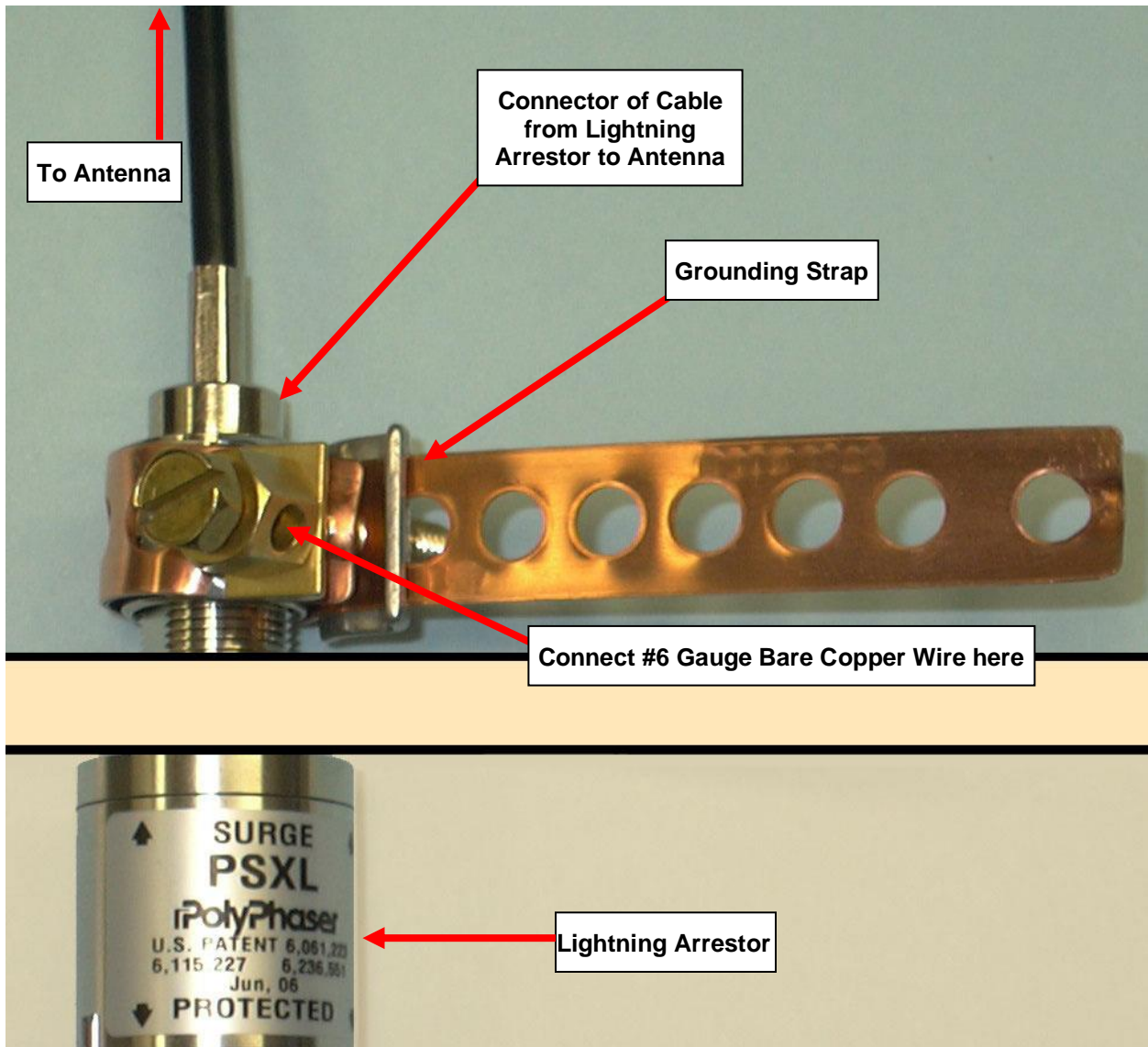

8 BASE STATION

The radio modem uses a 2.4 GHz frequency, so the radios may not penetrate a building. To get the best range between the 451 and the Base Station, the antennas should have a direct line of sight. An outside roof mount is desirable for the Base Station antenna. However, for an outside antenna, a lightning arrestor and a ground strap are required for safety.

The Nano (with RP-TNC adapter) and Spectra radios have a RP-TNC-Jack connector. The external antenna and lightning arrestor have N-Female connectors.

See **§6 OPTIONAL EQUIPMENT** for a complete list of radio modem accessories.

8.1 Base Station Setup

- Attach the antenna to the base station radio modem as shown. If an outdoor antenna is going to be used instead, see the notes at the end of this section.
- If the green terminal block does not have a power supply already attached to it, then test the power adapter wires with a multimeter to determine the '+' and '-' wires and connect the wires to the Vin+ and GND positions respectively.
- Connect the green terminal block to the radio as shown and plug the AC/DC power adapter into an AC power outlet. Always have an antenna connected when the radio is powered.



- Attach the serial communication cable to the radio modem's serial port and the PC's serial port. Modern PCs don't typically have a serial port. If necessary, install a serial card (StarTech 16950 UART card is preferred) or use a USB to RS232 adapter (P/N 990-0238).



- Install Jerome Monitor Software (JMS) to monitor the 451 instrument(s). See **§11 JEROME MONITOR SOFTWARE (JMS) INSTALLATION** for instructions.

INSTALLATION NOTES:

- If the base station antenna cannot be located in the 'line-of-sight' of a 451 or the 451 is out of range, a repeater can be used. If the 451 cannot be located within range of the base station, the Jerome 451 can run remotely and store up to 50,000 readings.
- If an outdoor antenna is used on the base station:
 - Connect an appropriate cable between the radio modem and the lightning arrestor. Refer to **§6 OPTIONAL EQUIPMENT** for information on the different available cables.
 - Next, connect an appropriate cable from the lightning arrestor to the outdoor antenna. See the diagram on the next page for an example setup.
 - **The lightning arrestor must be grounded to provide protection.** Use the Grounding Strap to ground the lightning arrestor to a metal water pipe running into the ground, grounding spike, or other appropriate means using #6-gauge bare copper wire. (Follow national/local codes). See the pictures on the following pages for assistance configuring the Grounding Strap.
 - For additional protection, install a lightning rod as well to protect the system.

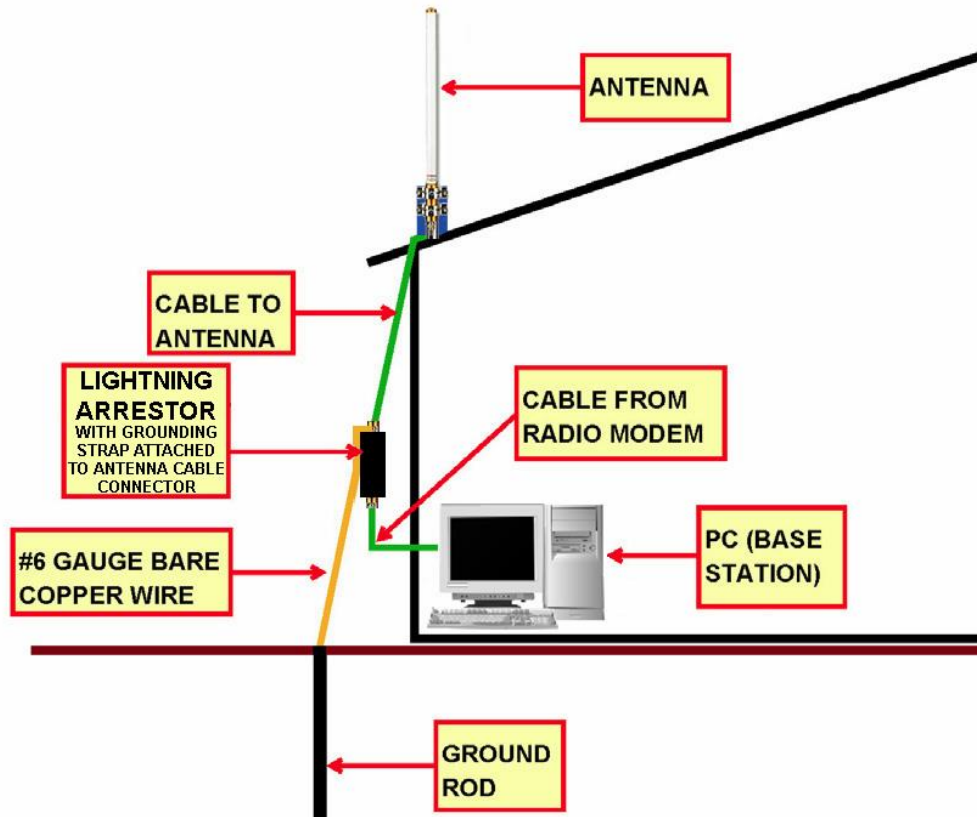

Example Base Station with Outdoor Antenna Setup

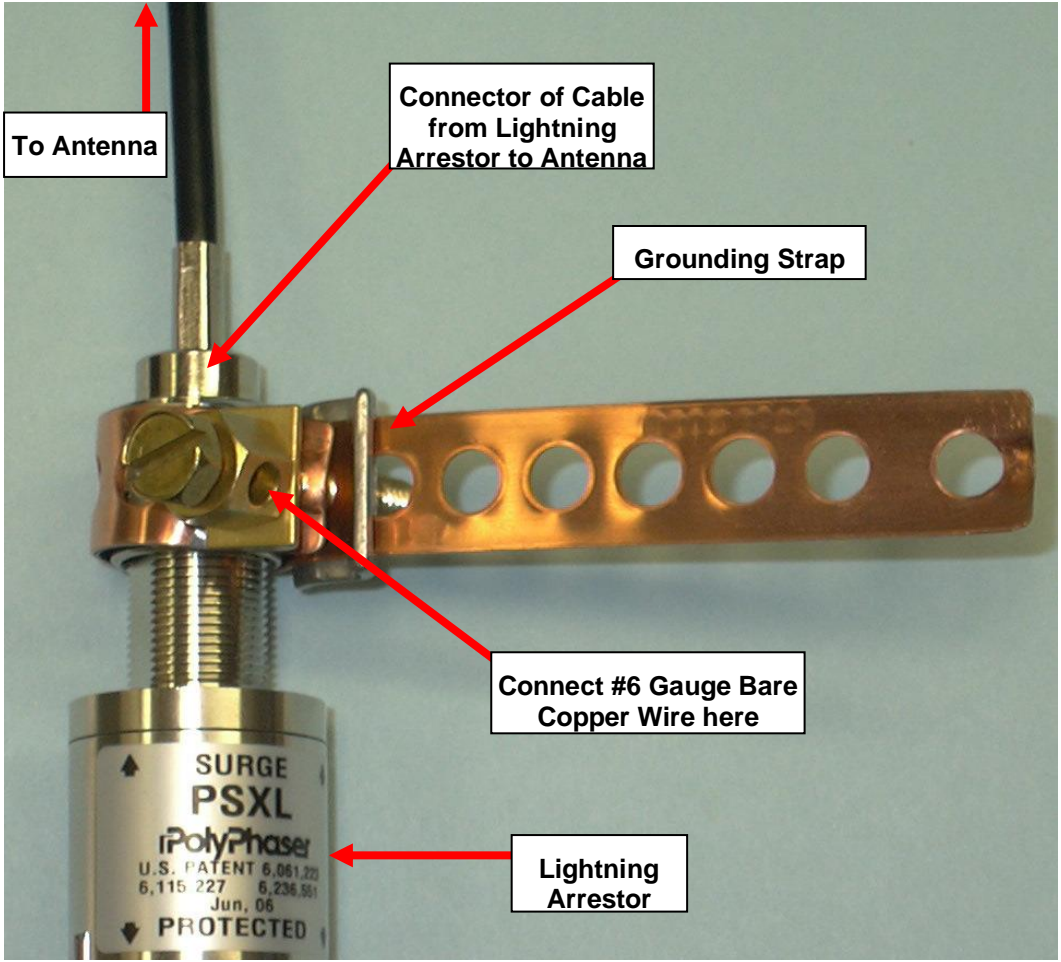

Detail of Grounding Strap & Lightning Arrester

9 451 USER INTERFACE

9.1 Status Items

Normally the instrument displays the H₉ vapor gas reading after exiting the menu system. Press [UP] and/or [DOWN] to view the other STATUS items: box temperature, time, date, wind direction, wind speed, and wind temperature. When scrolling through the status items, a description of the viewed item is displayed for 1 second. The description also displays periodically. The wind items are only available if the wind functionality is enabled in the SYSTEM menu.



When a system “ERROR” occurs, it is displayed on the status line and the instrument may stop operating depending on the error. The SYSTEM / RESET menu item can be used to reboot the 451, which clears the ERROR. Wait for the 431-X to stop sampling before using SYSTEM / RESET to avoid triggering a 431-X ERROR. If the error condition still exists, the ERROR will occur again. Contact Customer for details and assistance.

9.2 Selecting Menu Items

The following key presses are used to navigate the menus and select menu items:

- Press [SELECT] to enter the menus.
- Press [UP] or [DOWN] to change the selected menu item.
- Press [SELECT] to pick a submenu, parameter for editing, or an action item. Action items such as “SYSTEM / RESET” require a second press of [SELECT] to “CONFIRM?” the action.
- Press [ESCAPE] to cancel the action or selection.
- Press [ESCAPE] to exit a menu.



9.3 Editing Parameters

Once a parameter has been selected, the following key presses are used to edit the parameter:

- Press [UP] or [DOWN] to change the alphanumeric digit.
- Press [SELECT] to move right or save the parameter.
- Press [ESCAPE] to move left or not save the parameter.



9.4 Menu Tree

Use [UP] and [DOWN] to scroll through the STATUS items. Press SELECT and then use [UP] and [DOWN] to access the FTM CHK, SAMPLE, REGEN and SYSTEM submenus. Press SELECT again to make a selection. The Wind direction, speed and temperature status items will not appear if WIND functionality is not enabled in the SYSTEM menu.

451 MENU
STRUCTURE

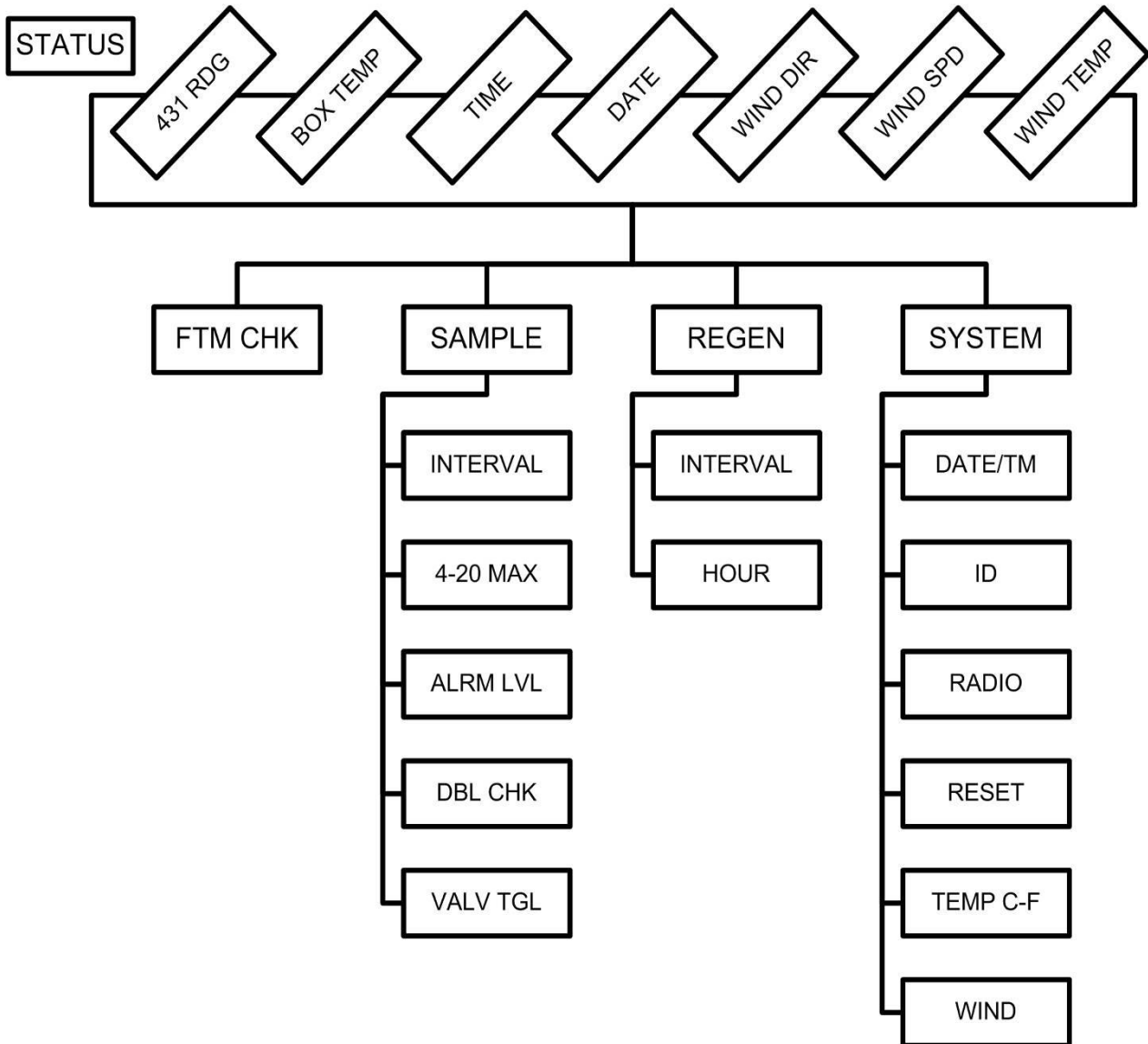

NOTE: The SYSTEM menu also contains a selection labeled FACTORY. This option is for factory use only and should not be accessed by the end user.

An explanation of the selections available from the menu system is listed in the table below.

MENU	SUBMENU	OPTIONS
STATUS Available at turn on and Escape	431 RDG	Measured gas concentration in mg/m ³
	BOX TEMP	Current box temperature
	TIME	Current time
	DATE	Current date
	WIND DIR	Wind direction (if WIND is enabled in SYSTEM menu)
	WIND SPD	Wind speed (if WIND is enabled in SYSTEM menu)
	WIND TEMP	Wind temperature (if WIND is enabled in SYSTEM menu)
FTM CHK		Use for Functional Tests of the instrument's response to Hg. See OPTIONAL FUNCTIONAL TEST OF 451/431-X , p.22
SAMPLE	INTERVAL	Select a sample interval of: 1, 2, 5, 10, 15, or 30 minutes, or 1 or 2 hours.
	4-20 MAX	Set the maximum reading level (in mg/m ³) that will correspond to a 20mA current from the 4-20mA connection on the main circuit board. See page 55 for details.
	ALRM LVL	XXX.XXX – Set the signal relay alarm level. Default is 0 (Disabled). See page 55 for details.
	DBL CHK	YES, NO – Set the double check high readings. Default is YES to repeat reading if a high level is taken. Only the second reading is saved.
	VALV TGL	Toggle valve. Default is 0 (No Toggle) DO NOT USE THIS MENU ITEM. FACTORY USE ONLY.
REGEN	INTERVAL	Set the periodic regeneration interval. 6, 12, 24, 48 hours. Default is 48 hours. An interval less than 48 hours will shorten the life of the gold film sensor in the 431-X.
	HOUR	## - Set the hour of the day to initiate the first regeneration. Default is 00, midnight. EXAMPLE: If interval is 12 and hour is 5, the regenerations will be at 5:00 AM and 5:00 PM. If interval is 6 and the hour is 4, the regenerations will be at 4:00 AM, 10:00 AM, 4:00 PM, and 10:00 PM.

SYSTEM	DATE/TM (time)	Edit the current month, day, year, hour, minute, and second.
	ID	Settings used to identify the instrument. <ul style="list-style-type: none"> • INSTRMNT - Contains up to 40 characters that are used to identify the instrument or location. • 431 SN - Contains the serial number of the installed 431-X instrument. Do not edit this value unless swapping 431-X's. • 451 SN - Contains the serial number of the instrument. Do not edit this value.
	RADIO	ADDRESS: ##### - The address of the radio modem in this 451. Valid input is 2 to 254. Default is 2. UP ADDR: The Up Address is set to 1 unless sending packets thru a repeater before reaching the base station radio; use repeaters address to send thru a repeater. RETRIES: The number of times the radio will try to send information to the base station. Valid input is 1 to 9. Default is 5. NET ID: ##### - The radio network ID. All radios on the same network must have the same ID. Valid input is 0 to 65535. Default is 1912. POWER: Set the TX (transmission) power level. Default is 1W.
	RESET	Resets the monitor and clears any errors. Turn off the 431-X before selecting this option.
	TEMP C-F	Select temperature displayed in either °F or °C.
	WIND	ENABLE: YES, NO – Enable wind gauge functionality. DIR CAL – NOTE: This is not typically used but can be used to get a high degree of accuracy from the wind gauge and calibrate the directional potentiometer. If done incorrectly, it could result in significant directional inaccuracy. The maximum resistance is displayed while the user slowly rotates the wind vane 2-3 rotations. The maximum resistance is at 355 degrees. Press [SELECT] to save the new calibration. TMP FACT – Set the compensation value for the external temperature probe for the effects of the internal box temperature. Default is 0.11. Do not edit this value.
	FACTORY	(Factory use only – DO NOT EDIT OR CHANGE DATA OR SETTINGS)

Some of these menu selections are also available for viewing and editing from the Jerome Monitor Software (JMS) PC. During 451 instrument setups, the RADIO ADDRESS and UP ADDR **must** be set at the instrument to enable PC access. If desired, SYSTEM / WIND / ENABLE and SAMPLE / DBL CHK functionality must be enabled at the instrument as well.

10 OPTIONAL FUNCTIONAL TEST OF 451/431-X

AMETEK Brookfield has a Mercury Functional Test Kit (FTK), P/N Y431 0902, that provides a fast and easy field test method of verifying that the 431-X is functioning correctly between recommended annual factory calibrations. It allows you to have complete confidence in the sample results. This test verifies proper instrument operation through the introduction of a known concentration of mercury vapor into the Jerome analyzer.



THIS VERIFICATION DOES NOT CALIBRATE THE INSTRUMENT.



If your application requires frequent verification of instrument function, this test demonstrates the unit's operation. Recording FTK results in an instrument log provides a quality control/quality assurance record of instrument function between regular calibrations. If test results fall within the expected range, you may assume the instrument is functioning correctly.

The Jerome 451 has a "FTM CHK" menu selection which will sample automatically. Instructions for use are supplied with the FTK. To order the FTK, contact Jerome Sales at (800) 528-7411 or (602) 470-1414.

10.1 Test Procedure

1. Set up and perform testing in accordance with the Jerome 431-X manual (P/N 700-0046) or the instructions with the Functional Test Kit (FTK) P/N Y431-0902, however, use the FTM CHK function in the 451 menu, instead of the sample button on the 431-X.
2. When ready to test, press [Select] to enter the menus; the 451 displays "FTM CHK."
3. Press [Select] again; the 451 displays "CONFIRM?"
4. Press [Select] once more and inject the mercury vapor when the display on the 431-X flashes.
5. Perform another injection each time the display on the 431-X flashes, for a total of seven (7) injections.
6. Average the last (5) samples and the average should be within the range provided with the Functional Test Kit.
7. Disconnect the FTK from the 451 and reconnect any "bug plugs" or drip controls to the intake tube.

8. Proceed to the next 451 (if applicable).
9. The data from (7) FTM samples will be retrieved by the JMS software the next time the 451 system is polled.

FTK Check readings will be automatically identified in the “Notes” column in the Data screen of the JMS software, so that they are not misinterpreted as regular sample readings. Through the software, the FTK data can also be viewed separately.

11 JEROME MONITOR SOFTWARE (JMS) INSTALLATION



NOTE: DO NOT LOAD ANY RADIO MODEM SOFTWARE FROM THE RADIO MODEM MANUFACTURER ON YOUR PC. ONLY LOAD THE JMS SOFTWARE INCLUDED WITH THE 451.



- JMS is provided on a USB flash drive or can be obtained from customer service.
- To install JMS, the user must be an Administrator on the target PC.
- If a version of JMS > 2.3 is already installed, it must first be removed using Windows Control Panel. Existing setup info and 451 data are preserved. If a version of JMS prior to v 2.3 is installed, it should be retained to view data from the earlier version, which cannot be viewed with JMS > 2.3.
- JMS can be installed on Windows 7 or 10 PCs. JMS requires 50 MB of free disk space; 500+ MB recommended for data storage.
- Open the directory that the JMS install files are located. Double click on the JMSSetup.msi using “My Computer” or “Windows Explorer” (Windows Key + E). “setup.exe” can be used instead if desired. Continue using the [Next] button.

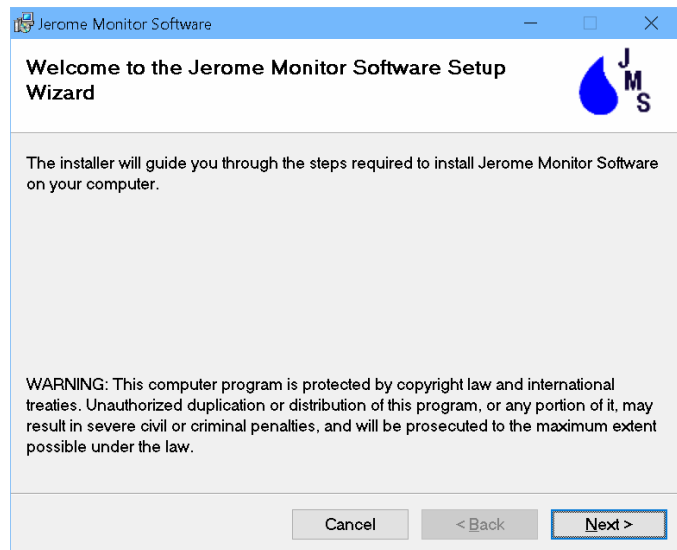

- The next window (not illustrated) displays the License Agreement, which must be accepted to install JMS. Read and select “I Agree”, then press the [Next] button.

- JMS is typically installed for “Everyone”. However, JMS is intended to run under a single user login. If multiple users use the JMS PC, then consider creating a single common user for JMS; users can login using the JMS login as needed. Continue using the [Next] button.

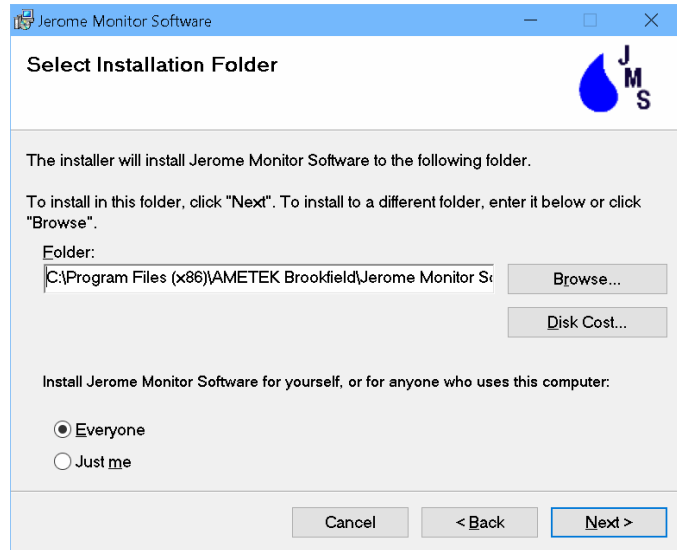

- Note, when installing using “Everyone” in Windows 10, the opposing compressed file arrows appear on the upper right of the desktop icon. The Windows start menu icon remains unaffected.



- The next screen is a confirmation screen. Continue using the [Next] button.
- The next screen is the Windows “User Access Control” screen. Enter an administration login if necessary.
- Next the program installs and completes.

11.1 USB Serial Port

If a USB serial port adapter is used, the PC’s hubs should be set to not power down. If the PC shuts down a hub, then all connected USB devices get shut down too.

As an administrator, open Windows “Device Manager”. Click the Windows key and type “dev”. Select “Device Manager” from the search list.

Under “Universal Serial Bus Controllers” look for items that have “Hub” in the description.

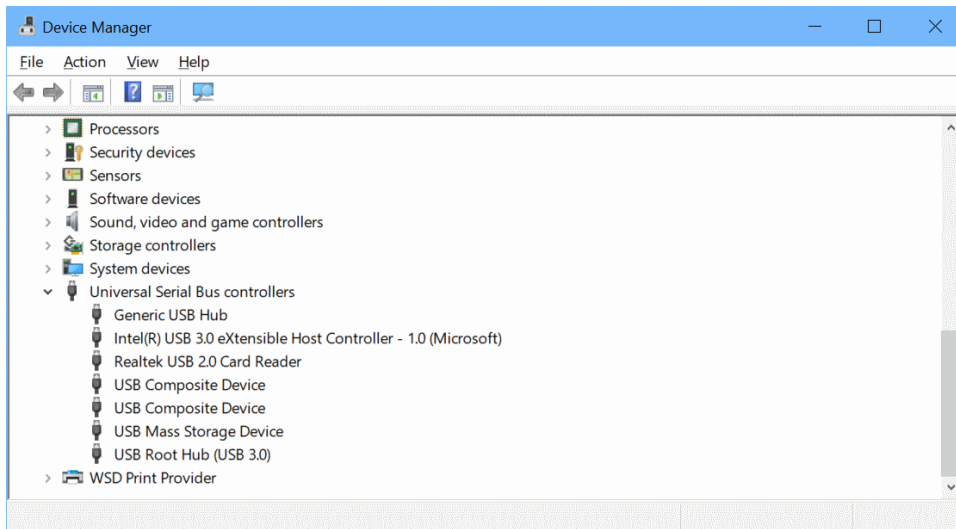

Double click a “Hub” item and select the “Power Management” tab. Select the “Power Management” tab and uncheck “Allow the computer to turn off this device to save power”. Repeat for additional hubs.

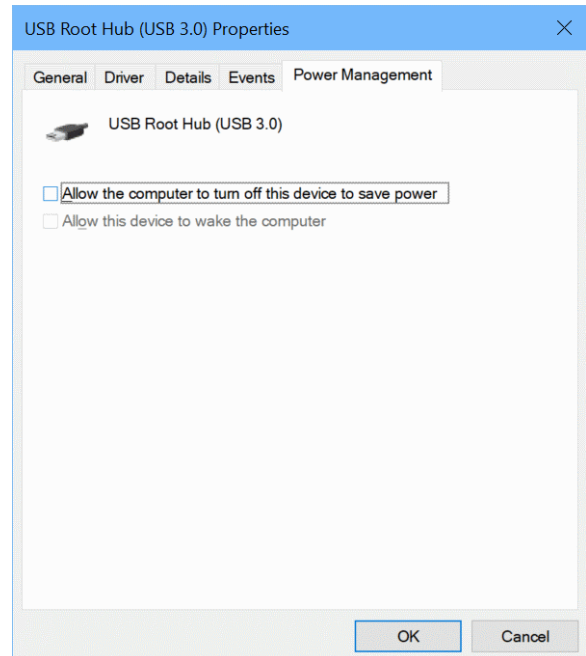
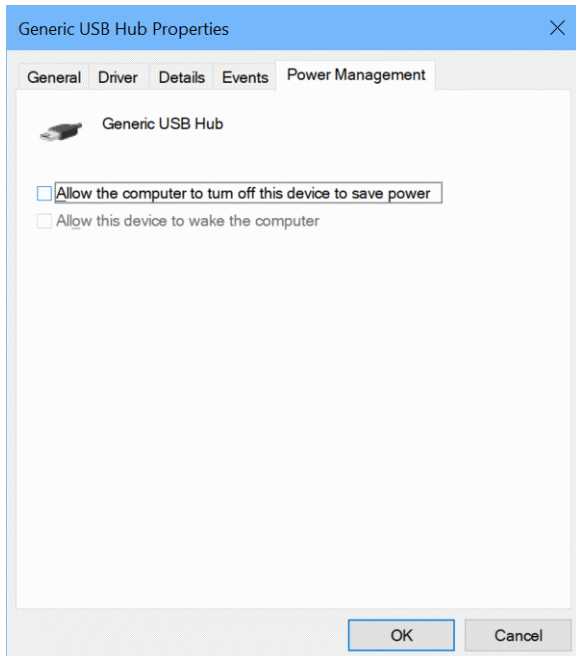

12 LAUNCHING JMS

The JMS software can interface with the Jerome 651 Fixed Point Hydrogen Sulfide Monitor as well as the Jerome 451 Fixed Point Mercury Monitor. Over 20 Jerome 451 or 651 instruments can be connected to the network of instruments. Operating JMS is the same whether 451s or 651s are used.

To start JMS: double click on the “Jerome Monitor Software” desktop icon or the click the “Jerome Monitor Software” icon on the Windows start menu.



13 JMS SETUP

The following information regarding the configuration and use of JMS is also available from the Help system (use F1) within JMS.

13.1 First Time Setup

- Make sure that your PC's clock is set correctly. JMS synchronizes the instrument's clock with the PC's clock each time it polls data. Data recorded after polling will have use the new clock setting.
- When the program first starts, a "No com port" message is displayed. Select [OK] to dismiss the message.

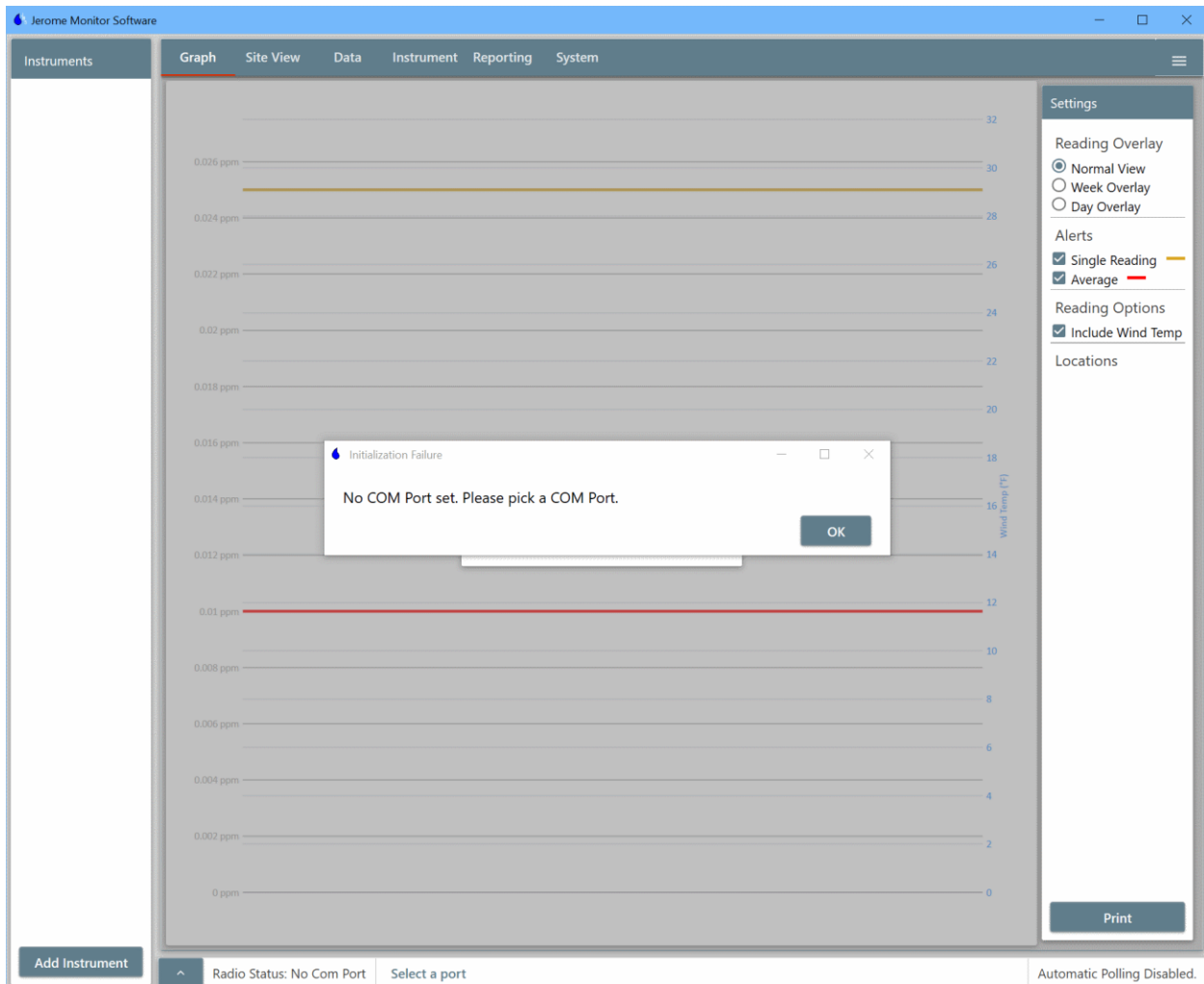

- The radio settings must be setup, which can be to by either:
 - Select "Select a port" text at the bottom of the screen.
 - Select the System Tab and then select the [Edit Settings] button.See **§13.2 Settings - System Options** for details.
- Add 451 / 651 instruments to the instrument list using the [Add Instrument] button on the lower left. See the Settings pane on Instrument Details Tab (**§14.4 Instrument Details Tab**) for details.

- Verify Radio Contact:
 - Ensure that the Radio Status at the screen bottom says “Ready”.
 - Click on an instrument the list on the left.
 - Select the [Sample] button to take a sample.
 - Approximately 40 seconds later, a popup message displays the result.
 - Select the [Poll] button to download the results from the instrument. The new result can be viewed on the Data Tab.

If you received a sample result back from your Jerome 451, the radios are communicating normally. If not, check the JMS help or **§14.7 Troubleshooting** for tips on resolving communication problems. For assistance, contact Customer Service.

13.2 Settings - System Options

Jerome Monitor Software Settings

System | Data | Email | Notifications

Radio Settings

COM Port: COM2

Radio Model: Nano

Repeaters:

Retries: 5

Net ID: 1912

Power: 100 mW

Site Location

Address: 3375 N Delaware St

City: Chandler

State: AZ

Zip: 85225

System Settings

Database Location: C:\Users\gjohnson\AppData\Roaming\JeromeMonitorSoftware\JMS.db

Re-Index Database

Run on User Login?

Save Cancel

Radio Settings (Far left):

Base station radio settings are configured:

- COM Port - Set to the serial communications port that is connected to the base station radio. A straight through DB9 pin cable is used.
- Radio Model - Select either the "Nano" or "Spectra 2400 Compatible". The "Spectra 2400 Compatible" radio has been used for legacy 451 installations, which is now obsolete. The Nano and Spectra 2400 Compatible radios cannot be mixed on a single site.
- Repeaters (Nano only) - Check this box if there are one or more repeaters on the site.

- Channel (Spectra 2400 Compatible only) - Set to a hopping channel number between 1 and 43. All radios talking directly to the base station radio (not thru a repeater) must be set to the same channel. If you are experiencing poor communication, there may be interference, so try a different channel.
- The Nano radios don't have a channel.
- Retries - Typically set to 5. Specifies the number attempts that the base station radio uses for a successful packet transmission. The instruments also have a Retries setting for transmitting packets to the base station radio.
- Net ID - Default is 1912 but can be set as desired. All radios must have the same setting.
- Power - The radio can have its transmit power reduced. The FCC requires that lower power (< 1W) be used if a high gain antenna is used.

Site Location (Right):

Setup the site address.

System Settings (Bottom):

- Database Location - The database location can be changed if desired. The database is an SQLite file, which can be read by other compatible programs. Note, the settings.xml file, which contains the program configuration, is stored in the default location. Both files should be periodically backed up. Corrupt polling (.log) files are stored in the default location for diagnostic purposes if needed. The (.log) files can be periodically deleted to save disk space; consider deleting (.log) files prior to backup.
- [Re-Index Database] - If JMS becomes slow processing readings, re-index the database.
- Run on User Login - Start JMS when the user logs in. JMS is intended to run under a single user login. If multiple users use the JMS PC, then consider creating a single common user for JMS; users can login using the JMS login as needed.

13.3 Settings - Data Options

The screenshot shows the 'Jerome Monitor Software Settings' window with the 'Data' tab selected. The settings are as follows:

Setting	Value
Enable Automated Polling:	<input type="checkbox"/>
Poll Interval (Minutes):	5
Days of Data to Display:	14
Primary Gas:	Hydrogen Sulfide (H2S)
Single Reading Alert Level (ppm):	0.025
Average Reading Alert Level (ppm):	0.01
Averaging Algorithm:	Time Weighted Average
Averaging Interval (Hours):	8
Temperature Unit:	°F
Wind Speed Unit:	mph
Wind Direction Unit:	Compass

Buttons: Save, Cancel

Data Handling Settings:

- Enable automated polling - Enables automated polling based on the specified interval. Current instrument data is retrieved during polling. Instruments store readings until the readings are cleared from the instrument.
- Poll Interval (Minutes) - Set the polling interval based on:
 - How current you want the data
 - How soon you want to be notified of a high reading (if popup or email notifications are turned on)
- Days of Data to Display - Controls the number of days shown on the Graph and Data tabs. A common value may be a multiple of 7 days; for example: 7, 14, 21, and 28 days.
- Primary Gas - Select "Mercury (Hg)" or "Hydrogen Sulfide (H2S)" for a 451 or 651 site respectively.
- Single Reading Alert Level (ppm or mg/m3) - When a single reading exceeds this level, a popup or email notification is sent if enabled.
- Average Reading Alert Level (ppm or mg/m3) - When the average reading exceeds this level, a popup or email notification is sent if enabled.

- Averaging Algorithm - "Time Weighted Average" or "Unweighted Timed Average"
 - Time Weighted Average (TWA) - Each reading carries a time weight from its reading time to the next reading (or the end of period for the last reading in the TWA period).
Each reading is multiplied by its time weight in seconds; all time weighted readings are summed; $TWA = \text{sum} / (\text{time from first reading to end of the TWA period in seconds})$.
 - Unweighted Timed Average - Sum the readings and divide by the reading count during the period.
- Averaging Interval (Hours) - Number of hours for each averaging period.
- Temperature Unit - °F or °C
- Wind Speed Unit - mph or kph
- Wind Compass Unit - Compass or Degrees

13.4 Settings - Email Options

The screenshot shows the 'Jerome Monitor Software Settings' dialog box with the 'Email' tab selected. The 'Server Settings' section includes fields for SMTP Server (192.168.1.1), SMTP Port (25), Use Authentication (unchecked), Use SSL (unchecked), From Name (Superman), From Address (superman@krypton.com), Server Login Name (Justice_League_HQ), and Server Login Password (masked with dots). A 'Send Test Email' button is located below these fields. The 'Email Recipients' section shows a list with 'batman@gothamcity.gov' and a 'Remove' button. A 'New' button is also present. At the bottom are 'Save' and 'Cancel' buttons.

Server Settings:

- SMTP Server - SMTP server name or IP address.
- SMTP Port - Server port number; default is 25.
- Use Authentication - Check if needed.
- Use SSL - Check if needed. Try checking for TLS too.
- From Name - From name for any sent emails.
- From Address - From address for any sent emails.

- Server Login Name: Enter server login name if needed.
- Server Login Password: Enter server login password if needed.

Email Recipients:

Notifications are sent to the listed recipients.

13.5 Settings - Notifications Options

The screenshot shows the 'Jerome Monitor Software Settings' dialog box with the 'Notifications' tab selected. The dialog has four tabs: System, Data, Email, and Notifications. Under 'Notifications', there are two checked checkboxes: 'Enable Popup Notifications' and 'Enable Email Notifications'. Below these are three alert settings, each with an 'Edit' button and a text box for customization:

- High Reading Alert:** Sent when a new reading is higher than the alarm level set in the data tab. Customization: High Level Alarm: %Reading%
Alarm Level: %InstantAlarmLevel%
- High Average Alert:** Sent when a the average value for a completed average period is higher than the average alarm level set in the data tab. Customization: High Average Alarm: %TwaAvg%
Alarm Level: %AverageAlarmLevel%
- High Temp Alert:** Sent when the temperature inside an instrument is higher than recommended by the manufacturer. Customization: Internal Temperature Alarm: %TempF%
Range 0.0 °C to 40.0 °C (32.0 °F to 104.0 °F)

At the bottom of the dialog are 'Save' and 'Cancel' buttons.

Notification Settings:

- Enable Popup Notifications - Popups can be enabled for high readings, high temperatures, maintenance reminders, and instrument errors.
- Enable Email Notifications - Emails can be enabled for High Reading Alert, High Average Alert, and High Temp Alert messages. Messages can be customized.

High Reading Alert Message:

The customizable message can be constructed from variable codes that are replaced when the message is generated.

Use the scroll bar for more variables.

Update Alert Message

Alert Message

High Level Alarm: %Reading%
Alarm Level: %InstantAlarmLevel%

Variables

JMS will replace these codes with data related to the alert.

%Reading%	The high reading causing the alarm.
%Units%	Units for the given reading.
%ReadTime%	The date and time the alarming reading was taken
%TempInt%	Internal temperature of the instrument at the time of the reading
%TempExt%	Ambient temperature around the instrument at the time of the reading
%WindDir%	Wind direction at the time the alarming reading was taken

Save Cancel

High Average Message:

The customizable message can be constructed from variable codes that are replaced when the message is generated.

Use the scroll bar for more variables.

Update Alert Message

Alert Message

High Average Alarm: %TwaAvg%
Alarm Level: %AverageAlarmLevel%

Variables

JMS will replace these codes with data related to the alert.

%AverageValue%	The average reading value for the period.
%AverageMax%	The highest reading recorded during the average period.
%AverageMin%	The lowest reading recorded during the average period.
%AverageStart%	The date and time the average period began.
%AverageEnd%	The date and time the average period ended.
%GasType%	The type of gas read by the instrument.

Save Cancel

High Temp Alert Message:

The customizable message can be constructed from variable codes that are replaced when the message is generated.

Use the scroll bar for more variables.

Update Alert Message

Alert Message

Internal Temperature Alarm: %TempF%
Range 0.0 °C to 40.0 °C (32.0 °F to 104.0 °F)

Variables

JMS will replace these codes with data related to the alert.

%Reading%	The high reading causing the alarm.
%Units%	Units for the given reading.
%ReadTime%	The date and time the alarming reading was taken
%TempInt%	Internal temperature of the instrument at the time of the reading
%TempExt%	Ambient temperature around the instrument at the time of the reading
%WindDir%	Wind direction at the time the alarming reading was taken

Save Cancel

13.6 Repeater Setup

Repeaters relay radio packets between the upstream radio (typically the base station radio) and a downstream radio (typically an instrument).

The Nano and Spectra 2400 Compatible radio networks work differently:

- Nano radios do not have separate hopping channels. The base station radio is always radio address 1. The repeater's Up Address is 1 unless it is sending packets thru another repeater before reaching the base station radio. Don't forget to check the Repeaters option in the Radio Settings pane of the System tab on the Settings form (§13.2 Settings - System Options).

For example:

- Base station radio is always at address 1. The base station radio talks to instruments (or repeaters) that have their Up Address set to 1.
- A repeater with Address 5 and Up Address 1 relays packets between the base station radio and the instruments with their Up Address set to 5.

- Spectra 2400 Compatible radios use separate hopping channels to create 2 or more separate networks that connect thru a repeater(s).

For example:

- Base station radio is set to hopping channel 2. The base station radio can talk to instruments (or repeaters) on hopping channel 2.
- A repeater with Primary channel 2 and Secondary channel 4 relays packets between the base station radio on channel 2 and the instruments on channel 4.

Note, instrument radios can be set as repeaters too.

The screenshot shows a software window titled "Edit Repeater" with a "Program" button. The main area is titled "Repeater Settings" and contains the following fields:

- Location: New Repeater
- Radio Address: 5
- Up Address: 1
- Retries: 5
- Power: 250 mW (with a dropdown arrow)

At the bottom of the window are three buttons: "Delete", "Save", and "Cancel".

Repeater Settings:

- Location - Enter the location ID.
- Radio Address - Each radio must have a unique radio address from 2 to 254. For the Nano radio, the base station radio address is 1.
- Up Address (Nano only) - The repeater's Up Address is 1 unless it is sending packets thru another repeater before reaching the base station radio.
- Primary Channel (Spectra 2400 Compatible only) - The repeater's Primary Channel is set to the base station's radio channel unless it is sending packets thru another repeater before reaching the base station radio. If connected to another repeater, then set the repeater's Primary Channel to the other repeater's Secondary Channel.
- Secondary Channel (Spectra 2400 Compatible only) - The repeater's Secondary Channel is set to a different channel. Instruments that have their Primary Channel

set to the repeater's Secondary Channel send packets to the base station thru the repeater.

- Retries - Typically set to 5. Specifies the number attempts that repeater radio uses for a successful packet transmission.
- Power - The radio can have it transmit power reduced. The FCC requires that lower power (< 1W) be used if a high gain antenna is used.

Repeater Programming:

Bring the repeater to the JMS PC. Select the [Program] button and follow the instructions. Under JMS normal operation (not repeater programming), the repeater settings are not used by JMS.

14 JMS OVERVIEW

The Jerome® Monitor Software (JMS) allows you to download data from one or more Jerome 451/651 instruments, stores it in a permanent SQLite database for future use, and displays the data in table or graphical form. JMS can be used for either 451s (Hg) or 451s (H2S) instruments.

JMS uses a Spectra or Nano radio modem connected to a PC or laptop to communicate with Jerome 451/651 instruments up to 4 miles away; see **§14.8 Fresnel Zone** for details. Jerome 451/651 instruments store their sample results in internal memory until "polled" by JMS. At that time, JMS downloads all of the stored results and saves them to a permanent database on the PC or laptop; the database and program settings location can be specified as needed. JMS displays the results in a table and on a graph. An optional weather station is available, which provides wind direction, speed, and temperature.

JMS can be set to automatically poll Jerome 451/651 instruments if the PC is set up within range of them. JMS automatically refreshes the data after polling the Jerome 451/651 instruments. If an internet connection is also present, JMS can email high H2S or Hg alerts and notifications of system errors to email addresses you supply. You can also manually poll Jerome 451/651 instruments in order to obtain the very latest data.

§13.1 First Time Setup will guide you through the typical steps for getting JMS running the first time.

JMS has tabs to view data and setup the site:

- **Graph Tab** - Graphs sample data without FTM/FTK readings.
- **Site View Tab** - Shows a site map view with instrument markers.
- **Data Tab** - Shows a tabular view of data over user a selectable number of days. Data can be filtered as needed.
- **Instrument Details Tab** - Tab has various areas:
 - Instrument status is shown. Manual samples can be taken.
 - Instrument settings (including sampling & regeneration intervals) are configured.
 - Reminders can be setup.
 - Historical events showing 451/651 instrument replacements are shown.
- **Reporting Tab** - Automated recurring reports are setup and reports can be generated as needed.
- **System Tab** – [Edit Settings] form has multiple tabs for program configuration:
 - **Settings - System Options** - Specify base station radio settings, site address, database location.
 - **Settings - Data Options** - Specify data handling settings
 - **Settings - Email Options** - Email server settings
 - **Settings - Notifications Options** - Enable and disable popups and emails, setup message text

If necessary, see **§14.7 Troubleshooting** for tips on resolving communication problems. For assistance, contact Customer Service.

14.1 Graph Tab

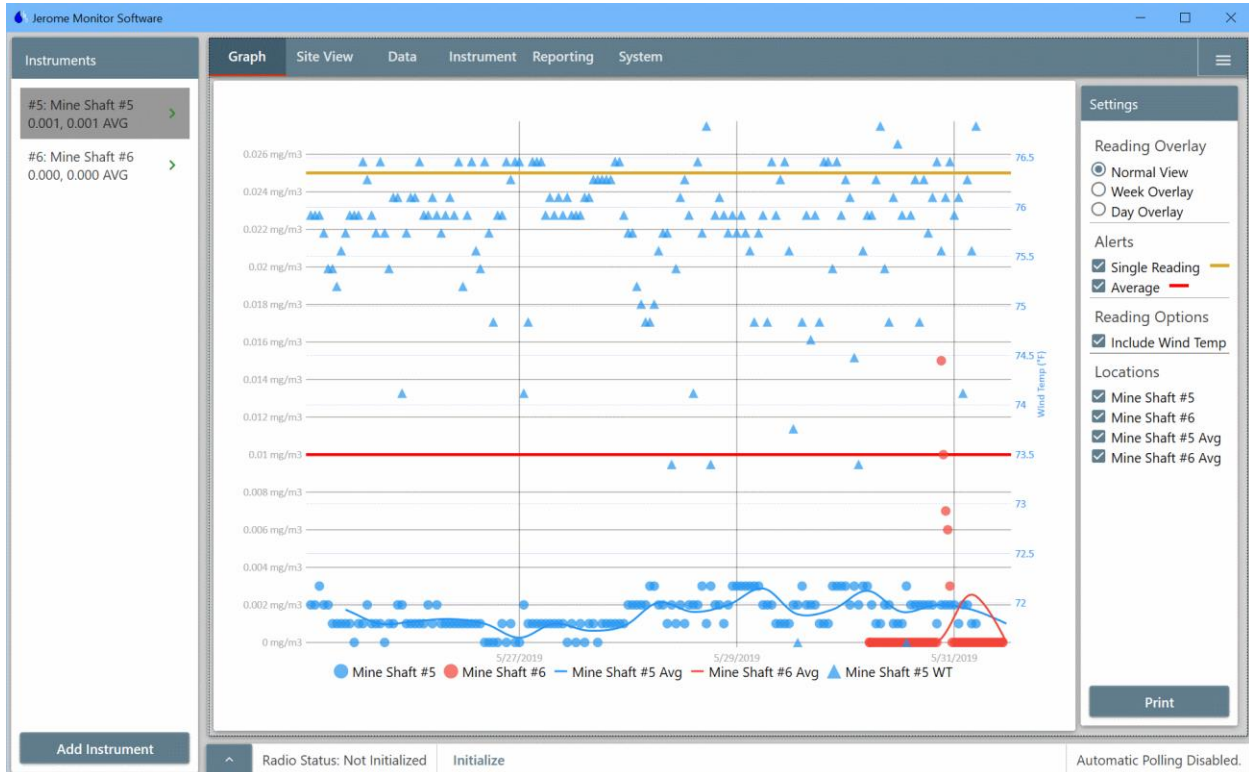

Graph (Middle):

The Graph tab displays readings in normal or overlaid view depending on the Reading Overlay type selected in the right pane. The Day Overlaying mode shows trends during times of the day. The amount of data shown is controlled by the "Days of Data to Display" on the Data tab (§13.3 Settings - Data Options) of the Settings form.

The alert levels can be optionally displayed. The levels are set on the Data tab (§13.3 Settings - Data Options) of the Settings form.

Select the desired filtering locations in the right pane.

[Print] prints the graph.

Instruments (Far Left):

Site instruments are listed. If an instrument is clicked on, then the Instrument Details tab is shown for that instrument.

[Add Instrument] adds a new instrument; see the Settings pane Help on the Instrument Details tab (§14.4 Instrument Details Tab).

Radio Status (Bottom):

- Radio Status - The status must be "Ready" before JMS can talk to instruments.
- Text may be shown right of the Radio Status like "Initialize" or "Poll Instruments Now". Clicking on the text will perform the action.
- Polling status is shown on the right side.

14.2 Site View Tab

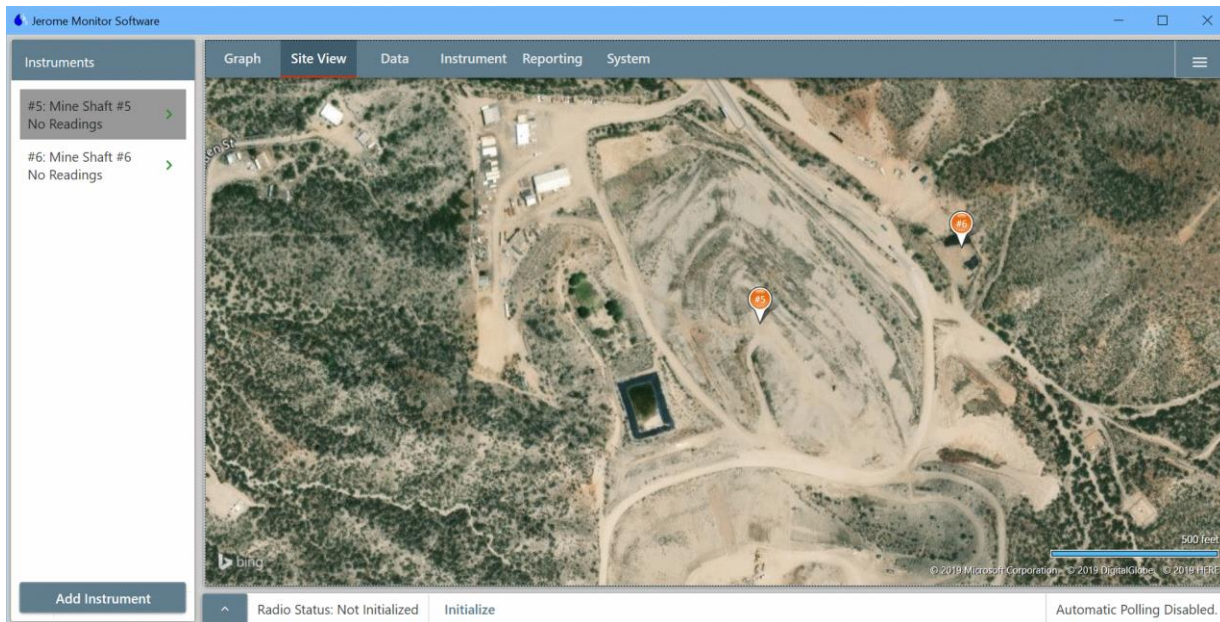

Map:

The map shows the locations of the instruments with pins. The pin heads can contain a designator, which is set using the instrument settings on the Instrument Details tab.

The view can be zoomed in/out with the mouse wheel.

Instruments (Far Left):

Site instruments are listed. If an instrument is clicked on, then the Instrument Details tab is shown for that instrument.

[Add Instrument] adds a new instrument; see the Settings pane Help on the Instrument Details tab (**\$14.4 Instrument Details Tab**).

Radio Status (Bottom):

- Radio Status - The status must be "Ready" before JMS can talk to instruments.
- Text may be shown right of the Radio Status like "Initialize" or "Poll Instruments Now". Clicking on the text performs the action.
- Polling status is shown on the right side.

14.3 Data Tab

The screenshot displays the Jerome Monitor Software interface. The top navigation bar includes tabs for Graph, Site View, Data, Instrument (selected), Reporting, and System. On the left, an 'Instruments' list shows '#5: Mine Shaft #5' and '#6: Mine Shaft #6'. The main area is titled 'Mine Shaft #5' and shows system details: System: 451-00020, Instrument: 431-00022, and Status: OK. Below this are buttons for Program, Poll, Sample, and Reset. An aerial map shows the location of Mine Shaft #5. The 'Settings' section includes fields for Location Name, Sample Every (60 Minutes), Regenerate Sensor Every (24 Hours), First Regen At (Midnight), Enable Polling (checked), Clear Data After Download (unchecked), Double-Check High Readings (checkbox), Radio Address (2), Pin Designation (#5), and Instrument Is Also a Repeater. The 'Reminders' section shows a 'Functional Test' reminder set for the first Sunday of each month at 9:00 AM. The 'History' table shows a single entry for 5/31/2019 with an initial poll. At the bottom, the status bar indicates 'Radio Status: Not Initialized' and 'Automatic Polling Disabled'.

Readings (Middle):

The Data tab displays either readings or averages depending on the Data Type selected in the right pane. Note, checking "Include Averages" will include averages with the readings. The amount of data shown is controlled by the "Days of Data to Display" on the Data tab of the Settings form.

Select the desired filtering options in the right pane. "Exclude Errors" excludes 431 / 631 errors like BRIDGE.

Columns can be sorted in ascending or descending order by clicking on the column header.

[Export to CSV] exports the data to a .csv file, which can be read by a spreadsheet or database.

Instruments (Far Left):

Site instruments are listed. If an instrument is clicked on, then the Instrument Details tab is shown for that instrument.

[Add Instrument] adds a new instrument; see the Settings pane Help on the Instrument Details tab (**§14.4 Instrument Details Tab**).

Radio Status (Bottom):

- Radio Status - The status must be "Ready" before JMS can talk to instruments.
- Text may be shown right of the Radio Status like "Initialize" or "Poll Instruments Now". Clicking on the text performs the action.
- Polling status is shown on the right side.

14.4 Instrument Details Tab

The screenshot shows the 'Instrument' tab in the Jerome Monitor Software. The interface is divided into several sections:

- Left Panel (Instruments):** Lists two instruments: '#5: Mine Shaft #5' (0.001, 0.001 AVG) and '#6: Mine Shaft #6' (0.000, 0.000 AVG). A green arrow points to the right for each.
- Top Navigation:** Includes tabs for Graph, Site View, Data, Instrument (selected), Reporting, and System.
- Main Content Area:**
 - Mine Shaft #5:** System: 451-00020, Instrument: 431-00022, Status: OK. Below are buttons for Program, Poll, Sample, and Reset.
 - Settings:** Includes fields for Location Name (Mine Shaft #5), Sample Every (60 Minutes), Regenerate Sensor Every (24 Hours), First Regen At (Midnight), Enable Polling (checked), Clear Data After Download (unchecked), Double-Check High Readings (Can Be Configured at the Instrument), Radio Address (2), Pin Designation (#5), and Instrument Is Also a Repeater (unchecked). An 'Edit' button is present.
 - Reminders:** A 'New' button and a reminder card for 'Functional Test' (Every month on the first Sunday at 9:00 AM, Next: 06/03/2019 9:00 AM) with an 'Edit' button.
 - History:** A table with columns: Date, Detail, New Serial, Previous Serial. One entry is shown: 5/31/2019, Initial Poll, 431-00022, Unknown.
- Bottom Bar:** Shows 'Radio Status: Not Initialized' with an 'Initialize' button and 'Automatic Polling Disabled'.

The Instrument Details tab has multiple sections for instrument details.

Instruments (Far Left):

Site instruments are listed. If an instrument is clicked on, then the Instrument Details tab is shown for that instrument. [Add Instrument] adds a new instrument; see the Settings pane help below.

Instrument Details (Top Middle):

The instrument status is shown for a specific instrument when clicking on the instrument in the left pane.

Specific actions can be performed to the instrument thru the buttons:

- [Program] - After making changes to the instrument settings, click the [Program] button to program the instrument with the new settings.
- [Poll] - Poll the individual instrument now even if the instrument polling is disabled.
- [Sample] - Perform a manual sample. Approximately 35 to 40 seconds later, a message is displayed showing the reading.
- [Reset] - Reset the instrument. Resetting the instrument can clear a system error. Avoid resetting an instrument while it's sampling, which could trigger a 431/631 system error. For example, if the instrument sample interval is 30 minutes, then don't perform a reset during 00 and 30 minutes after the hour.

Map (Top Right):

The map shows the location of the selected instrument. If the location has not been previously set, then a message is shown indicating how to set it.

Settings (Middle):

Click the [Edit] button to change the instrument settings.

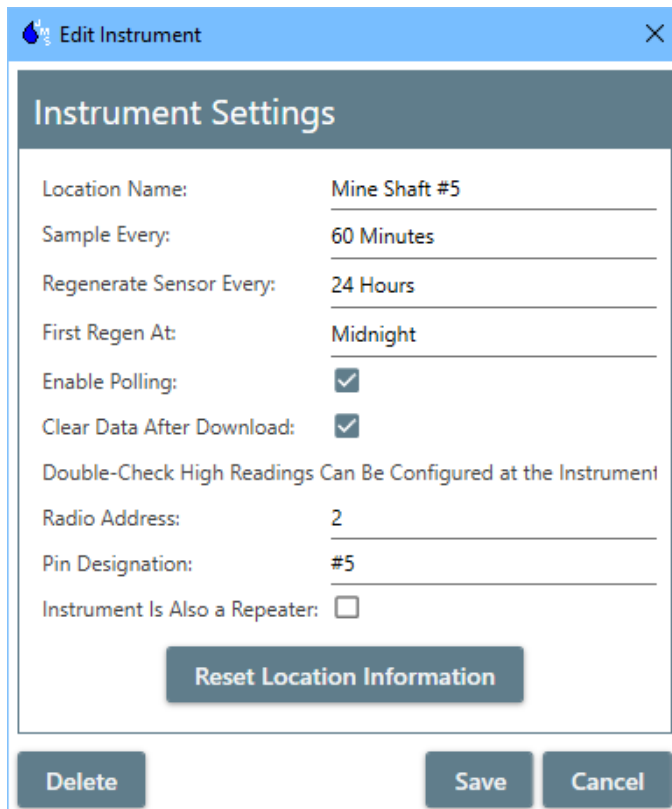

The screenshot shows a software window titled "Edit Instrument" with a close button (X) in the top right corner. The main content area is titled "Instrument Settings" and contains the following fields and controls:

Location Name:	Mine Shaft #5
Sample Every:	60 Minutes
Regenerate Sensor Every:	24 Hours
First Regen At:	Midnight
Enable Polling:	<input checked="" type="checkbox"/>
Clear Data After Download:	<input checked="" type="checkbox"/>
Double-Check High Readings:	Can Be Configured at the Instrument
Radio Address:	2
Pin Designation:	#5
Instrument Is Also a Repeater:	<input type="checkbox"/>

Below the settings fields is a button labeled "Reset Location Information". At the bottom of the dialog are three buttons: "Delete", "Save", and "Cancel".

Fields:

- Location Name - Enter the location ID.
- Sample Every - Available values are 1, 2, 5, 10, 15, 30, 60, and 120 minutes.
Aim to keep 451 samples < 100 readings per regeneration.
Aim to keep 651 samples < 150 readings per regeneration.
WARNING! Sample intervals less than 15 minutes will significantly reduce the life of the gold film sensor in the Jerome 431-X (or 631-X).
- Regenerate Sensor Every - Available values are 6, 12, 24, and 48 hours. The default is 48 hours.
An interval less than 48 hours will shorten the life of the gold film sensor in the 431-X (or 631-X).
- First Regen At - Regeneration takes an hour (no sampling), so pick a time when sampling is not required. If regen interval is 12 hours and first regen is 12AM, then the instrument will regen at 12AM and 12PM.
- Enable Polling - This is usually checked. Leave it unchecked if this instrument is offline.
- Clear Data After Download - This should be checked. Typically, data is deleted after successful polling. If unchecked, the instrument will store readings until full (50k+ readings), which will take excessive time to download during polling. For sites with difficult radio topology, transmission time must be minimized.
- Double-Check High Readings Can Be Configured at the Instrument - This is set on the instruments SAMPLE / DBL CHK menu.
- Radio Address - Each instrument must have a unique radio address from 2 to 254. The address in JMS must match the instrument. For the Nano radio, the base station radio address is 1. See the instrument SYSTEM / RADIO menu (**\$9.4 Menu Tree**) to program the instrument radio.
- Pin Designation - A 1 or 2 digit designation that is used for the map display. If specified, then the designation prefixes the instrument location name in the instruments list.
- Instrument Is Also a Repeater - Instrument radios can be set as a repeater to other instruments that don't have a line of site to the base station radio. Instrument radio repeater settings are set at the instrument. This JMS field is only for informational purposes and has not functional impact.
- [Reset Location Information] - Use this button to clear the current instrument pin location on the Site View tab.

Reminders (Middle Right):

For each instrument, calibration and functional test reminders can be set as needed. The popup and email options in the Notification tab (**§13.5 Settings - Notifications Options**) on the Settings form controls how the reminders are sent.

The screenshot shows a window titled "Edit Reminder" with a blue header bar. Below the header is a dark grey bar with the text "Reminder Settings". The main area contains two radio buttons: "Calibration" (selected) and "Functional Test". Below these are four input fields: "Period" (set to "Years"), "Time of Day" (set to "8:00"), "Month" (set to "May"), and "Day" (set to "2"). At the bottom are three buttons: "Delete", "Save", and "Cancel".

History (Bottom Right):

JMS records 431/631 changes for an instrument. When 431/631s are sent in for calibration, a different 431/631 may be installed in the instrument. If the instrument menu SYSTEM / ID / 431 SN (or 631 SN) is updated, then JMS records the change in History.

Radio Status (Bottom):

- Radio Status - The status must be "Ready" before JMS can talk to instruments.
- Text may be shown right of the Radio Status like "Initialize" or "Poll Instruments Now". Clicking on the text will perform the action.
- Polling status is shown on the right side.

14.5 Reporting Tab

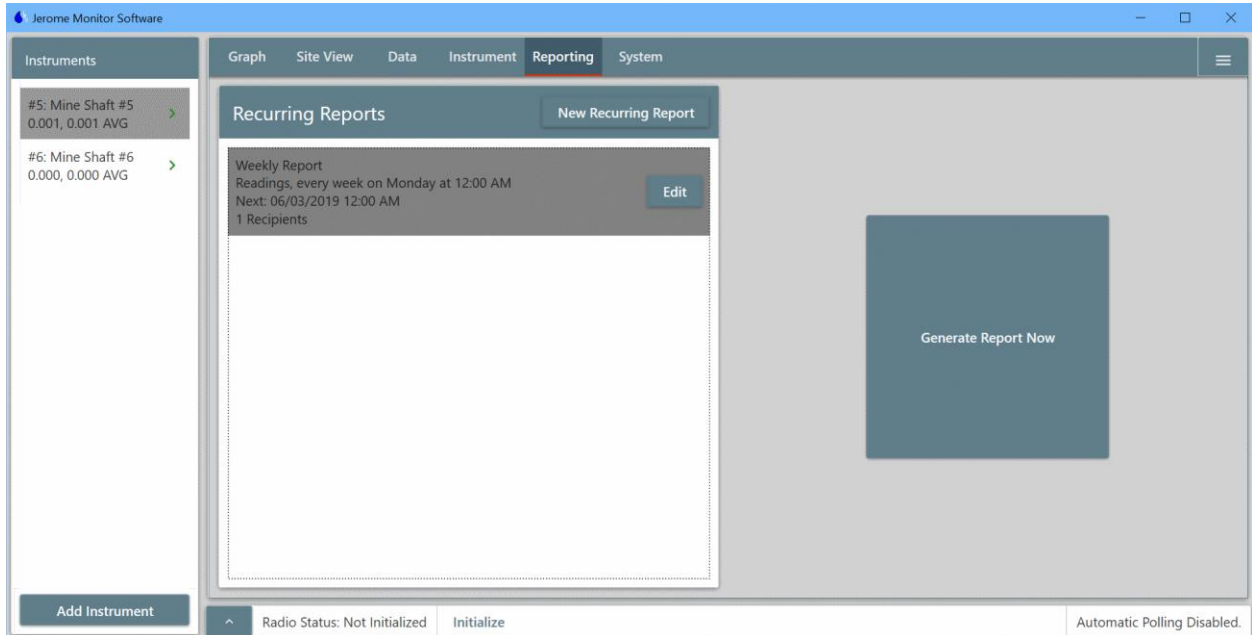

The Reporting tab can setup recurring reports and generate reports on demand.

Recurring Reports (Top Middle):

Recurring reports can be created as needed. The reports are emailed to the designated addresses.

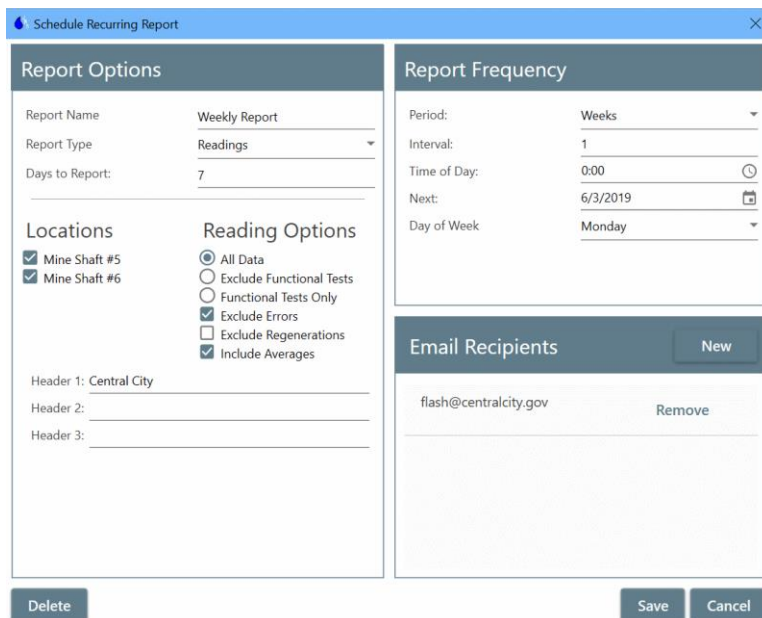

Report settings:

- Report Name - Set as desired
- Report Type - The following reports are available:
 - Readings - Reports the 431/631 readings.
 - Averages - Averages are based on the settings in the Data tab on the Settings form.
 - Instrument History - Reports the 431/631 changes for the instruments.
 - System Setup - Reports the JMS setup.
- Days to Report - The number of days to include in the report starting from the date of the report working back in time.
- Locations - The instruments to include in the report is configurable.
- Reading Options - Select the desired filtering options. "Exclude Errors" excludes 431 / 631 errors like BRIDGE.
- Header 1-3 - The header is printed on the upper right of the report. When saving the report, the header is saved as default for newly created reports.
- Report Frequency - The following periods are available:
 - Days
 - Weekdays - Day of Week is available
 - Weeks
 - Months - By Day or By Week is available
- Interval - How often the report is generated.
- Time of Day - The time that the report is generated, and the time that is used for filtering the data.
- If a daily report is selected at 8:00 with 1 day to report, then data will be from yesterday at 8:00 to today at 8:00 (exclusive).
- Email Recipients - List of addresses to receive the report.

Generate Report Now (Top Right):

Reports can be generated on demand. Report options are equivalent to the recurring reports.

Generate Report

Report Options

Report Type: Readings

Start Date: 5/24/2019

End Date: 5/31/2019

Time of Day: 0:00

Locations Reading Options

Mine Shaft #5 All Data

Mine Shaft #6 Exclude Functional Tests

Functional Tests Only

Exclude Errors

Exclude Regenerations

Include Averages

Header 1: Central City

Header 2:

Header 3:

Generate Report Cancel

Instruments (Far Left):

Site instruments are listed. If an instrument is clicked on, then the Instrument Details tab is shown for that instrument.

[Add Instrument] adds a new instrument; see the Settings pane Help on the Instrument Details tab (**\$14.4 Instrument Details Tab**).

Radio Status (Bottom):

- Radio Status - The status must be "Ready" before JMS can talk to instruments.
- Text may be shown right of the Radio Status like "Initialize" or "Poll Instruments Now". Clicking on the text performs the action.
- Polling status is shown on the right side.

14.6 System Tab

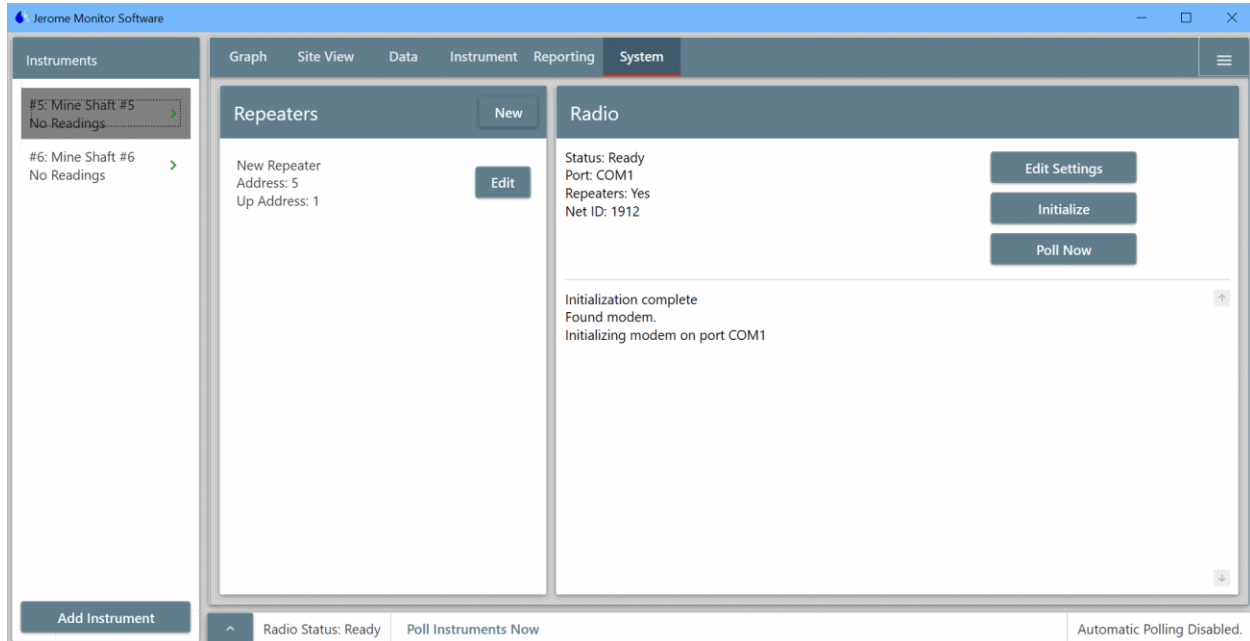

The System tab has multiple sections for site and program configuration:

Repeaters (Middle):

Some sites may require a separate repeater to reach instruments that are not visible to the base station radio.

Prior to installing a repeater, setup the repeater with JMS.

Use the [New] or [Edit] button to add or edit a repeater; see **§13.6 Repeater Setup**.

Radio (Right):

Radio Status in the upper left:

- The status must be "Ready" before JMS can talk to instruments. If necessary, the [Initialize] button can be selected to initialize the radio again.
- Key base station radio settings are shown.

The [Edit Settings] button changes program settings; see **§13.2 Settings - System Options**.

For JMS setup, configure the base station radio first.

The [Initialize] button initializes the radio. If the radio was disconnected, the radio can be initialized again if needed. If the radio has failed, the bottom Radio Status pane will show "Initialize" to the right of the status, which can be clicked to initialize the radio too.

The [Poll Now] button polls all instruments that have polling enabled.

The bottom Radio Status pane may show "Poll Instrument Now", which can be clicked to poll all instruments too.

Below the buttons, recent radio events are shown. The information can be used for troubleshooting.

Instruments (Far Left):

Site instruments are listed. If an instrument is clicked on, then the Instrument Details tab is shown for that instrument.

[Add Instrument] adds a new instrument; see the Settings pane Help on the Instrument Details tab (**§14.4 Instrument Details Tab**).

Radio Status (Bottom):

- Radio Status - The status must be "Ready" before JMS can talk to instruments.
- Text may be shown right of the Radio Status like "Initialize" or "Poll Instruments Now". Clicking on the text performs the action.
- Polling status is shown on the right side.

14.7 Troubleshooting

The radio will not initialize:

- Check the connection to the "COM Port" setting on the System tab (§13.2 **Settings - System Options**) of the Settings form.
- Check that JMS is set for the correct "COM Port".

There are communication errors reported by one or more instruments:

- Verify that the Jerome 451/651 is set up correctly according to the manual.
- Check that the correct "Radio Model" (Nano) is selected on the System tab (§13.2 **Settings - System Options**) of the Settings form.
- If using Spectra radios, check that JMS and the Jerome 451/651 instruments are on the same radio "Channel".
- Check that the radio address in the instrument settings on the **Instrument Details Tab** matches the radio address on the Jerome 451/651.
- Check the position of the radio antenna on the base station radio and the Jerome 451/651. Make sure that there is line-of-sight visibility, and the equipment is within the working range of the radio. See §14.8 **Fresnel Zone** for details.

JMS consistently encounters errors while downloading sample data:

- Check the position of the radio antenna on the base station radio and the 451/651. Make sure that there is line-of-sight visibility.
- If using Spectra radios, try setting JMS and the 451/651 to a different channel. If there is interference from another radio source, using a different channel may avoid it.
- Increase the radio "Retries" on JMS and the 451/651. See "Retries" setting on the System tab (§13.2 **Settings - System Options**) of the Settings form. See menu SYSTEM / RADIO / RETRIES on the 451/651.
- Verify that the Windows Language setting is set to "English".

The date and/or time of downloaded sample data is wrong:

- Check the clock on the JMS PC. JMS synchronizes the 451/651's internal clock with the PC's clock each time it polls data.

Verify that your PC meets the requirements necessary to run JMS:

- Windows 7 or 10.
- JMS requires 50 MB of free disk space; 500+ MB recommended for data storage.
- JMS has been tested under US-English versions of Windows. Compatibility with other language versions cannot be guaranteed.

To install JMS, the user must be an Administrator on the target PC:

- See your IT department for assistance.

14.8 Fresnel Zone

Radio Frequency (RF) line of sight is required to achieve maximum range with the Spectra radios used with the Jerome 451/651 instruments. RF line of sight differs from visual line of sight as shown in the figures below. The Fresnel Zone is an elliptical volume of space between the two antennas. Any objects within this space block a portion of the signal, and the radios are not able to transmit to their maximum range.

If the antennas are low enough, the ground itself blocks part of the signal.

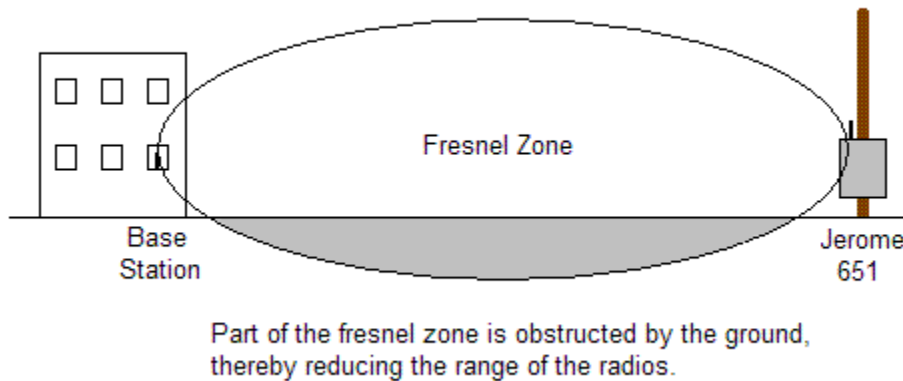

Placing the antennas higher up will prevent the ground from entering the Fresnel zone and improve the radio signal.

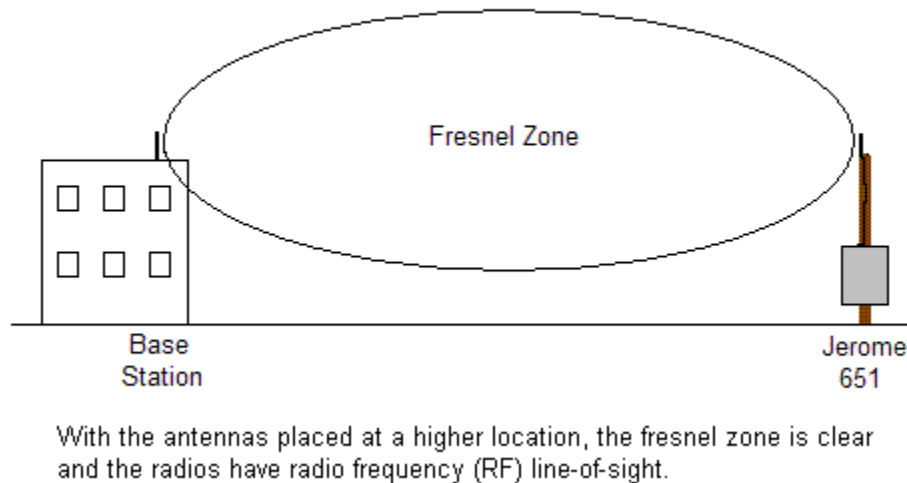

The Fresnel Zone is tabulated for 2.4 GHz at different distances. Recommended obstruction should be 20% or less. This can be used as a guide to help determine how high to place your antennas if you are experiencing radio communication problems with the 451/651 instruments.

Range Distance	80% Fresnel Zone Radius
1000 ft. (300 m)	8 ft. (2.4 m)
1.0 mile (1.6 km)	19 ft. (5.7 m)
2.0 mile (3.2 km)	26 ft. (8.0 m)
5.0 mile (8.0 km)	42 ft. (12.6 m)
10 mile (16 km)	59 ft. (17.9 m)

The basic rule is to make sure that the combined height of the base station and instrument antennas is greater than the radius of the Fresnel Zone.

Buildings and trees in the Fresnel Zone can also block a portion of the signal. Trees are a particular problem for 2.4 GHz radios. Although 2.4 GHz signals can pass through walls, they have a harder time passing through trees due to the water content.

Occasional communication errors due to interference are normal in urban areas or in bad weather. The Jerome 451/651 instruments store sample data until the radio is clear enough to send it.

15 FLOW PUMP KIT

A Flow Pump Kit (P/N Y990-0195) is available for the 451. The Flow Pump Kit has the ability to draw air for sampling over a long distance and still provide continuous real-time readings. Contact your Technical Sales for more information.

Line power of 100-240V AC, 50/60 Hz must be run to the marked connections of the terminal block in the flow pump. Maximum current draw is 1 Amp.



INSTALLATION:

1. The flow pump should be mounted a minimum of 6" higher than the "T" fitting.
2. Cut three (3) pieces of 3/8" OD Tubing to the appropriate lengths to be used where indicated in **red** in the diagram below:
 - From the measurement point to the flow pump inlet.
 - From the flow pump outlet to the included "T" fitting (P/N 1300-0062)
 - From the "T" fitting as an exhaust outlet to an ambient pressure location.
3. If using soft tubing, install the included inserts (P/N 1300-0064) in the ends of the tubing where it will connect to the flow pump and the "T" fitting. (The inserts prevent the tubing from being pinched shut).
4. Install the tubing where indicated and tighten the compression nuts to hold the tubing in place.
5. Connect the "T" fitting to the 451 intake and tighten the compression nut to secure it.

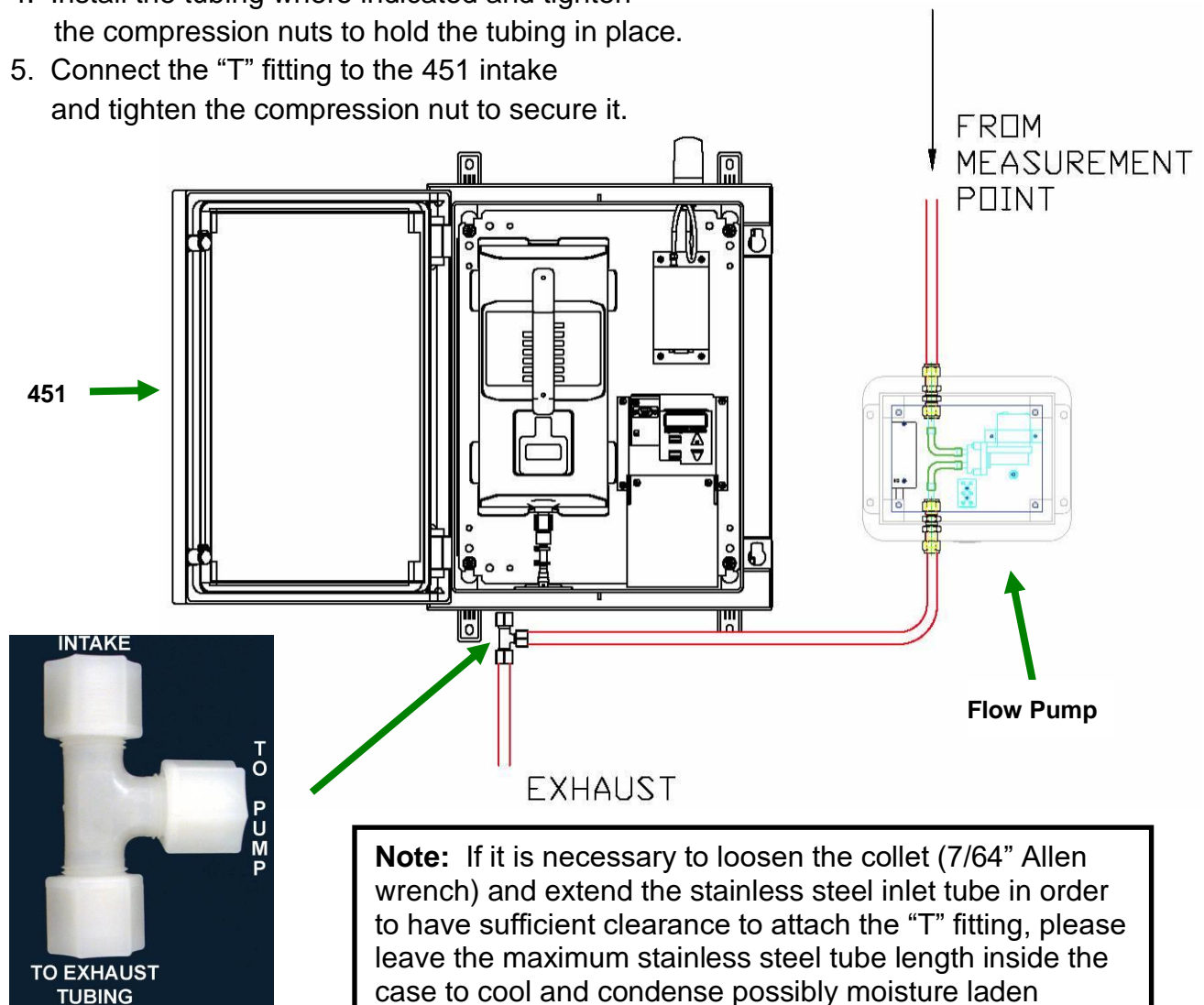

"T" Fitting (P/N 1300 0062)

16 4-20 MILLIAMP AND SIGNAL RELAY CONNECTIONS

The 451 provides both a 4-20 mA connection and a signal relay connection on the circuit board. Remove the two screws securing the Circuit Board Cover to access these connections on the circuit board.

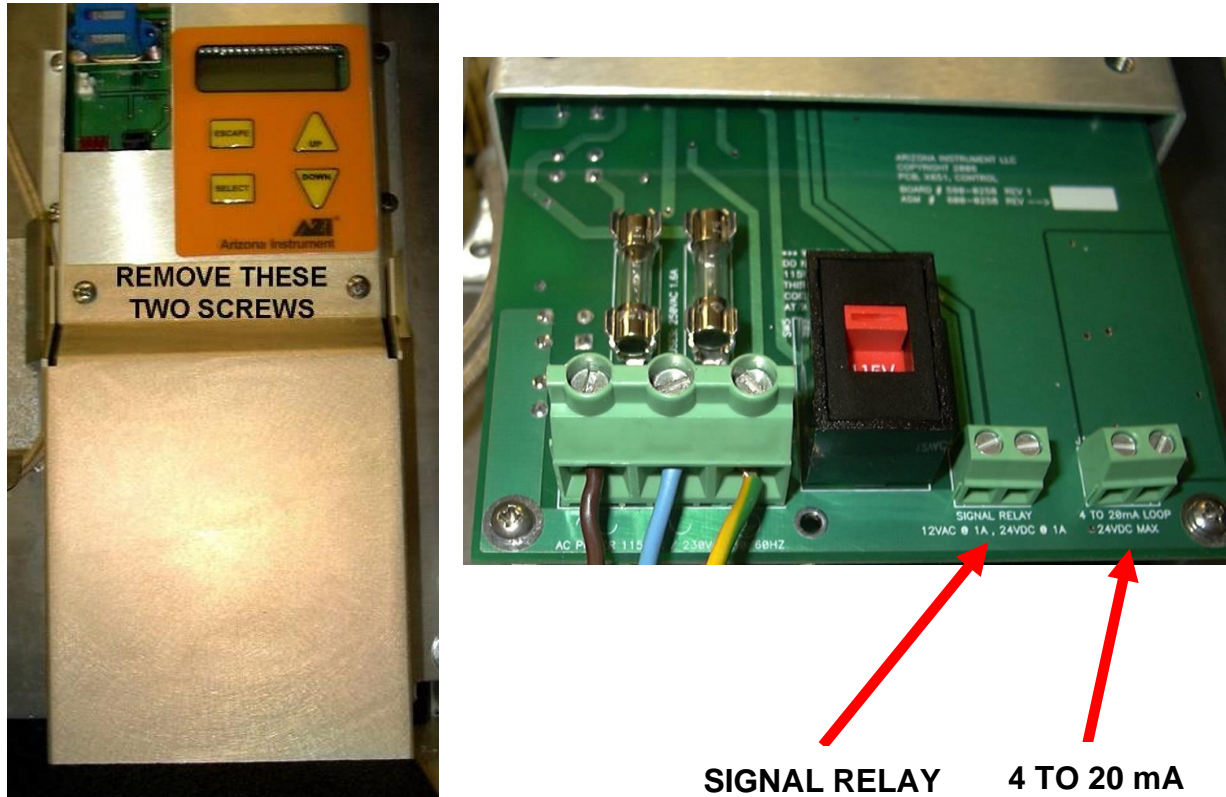

Once the desired connections have been implemented, replace the Circuit Board Cover and two screws.

16.1 4-20 mA

The 4-20 mA connection can be used to indicate the Hg reading level on a proportional scale from 4-20 milliamps for connection to certain industrial systems, such as SCADA.

A 4-mA current level always corresponds to an Hg reading of 0.000 mg/m^3 . The 20-mA level can be set as high as the maximum reading level for the 451 (0.999 mg/m^3) or somewhere between 0.000 and 0.999 mg/m^3 , depending on your application.

The 20-mA current level **must** be set to an Hg reading level before the 4-20 mA connection can be used. This value can only be set at the 451 and cannot be set using Jerome Monitor Software (JMS).

- Select 4-20 MAX from the SAMPLE menu to assign the Hg concentration (in mg/m³) for the 20 mA level.

After the 20 mA level has been set, the following equation can be used to determine the Hg reading based on the level of current.

$$\text{Hg concentration detected} = (\text{current in mA} - 4) \times (\text{4-20 MAX value})/16$$

For example, if the 4-20 MAX value is set to 0.999 mg/m³, the equation becomes:

$$\text{Hg} = (\text{current in mA} - 4) \times (0.999/16)$$

Thus, in this example using a 4-20 MAX value of 0.999 mg/m³, a 20 mA current corresponds to an Hg concentration of 0.999 mg/m³, while a 12 mA current corresponds to an Hg concentration of 0.500 mg/m³.

The 4-20 mA connection is passive and must be powered by an external 12 VDC power supply. An example setup is shown below.

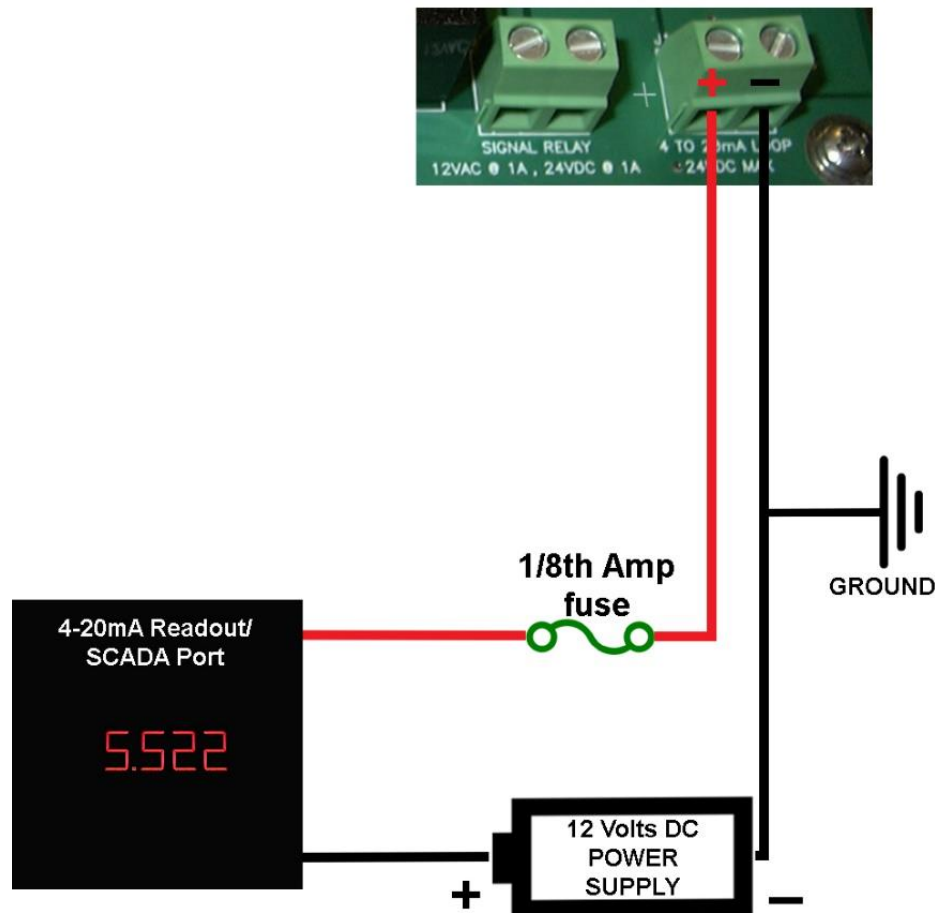

16.2 Signal Relay

The signal relay connection is an electrical switch that can be closed by the 451 when the 451 reads H₂S levels greater than or equal to the value set in ALRM LVL in the SAMPLE menu on the 451. This level can only be set at the instrument and cannot be set using JMS.

An appropriate audio or visual alarm can be connected to the signal relay. When the sample reading exceeds the designated level, the switch is closed, activating the connected alarm.

An example setup using the signal relay is shown below. The connected power supply cannot exceed 24 Volts DC and 1 amp of current or 12 Volts AC and 1 amp of current.

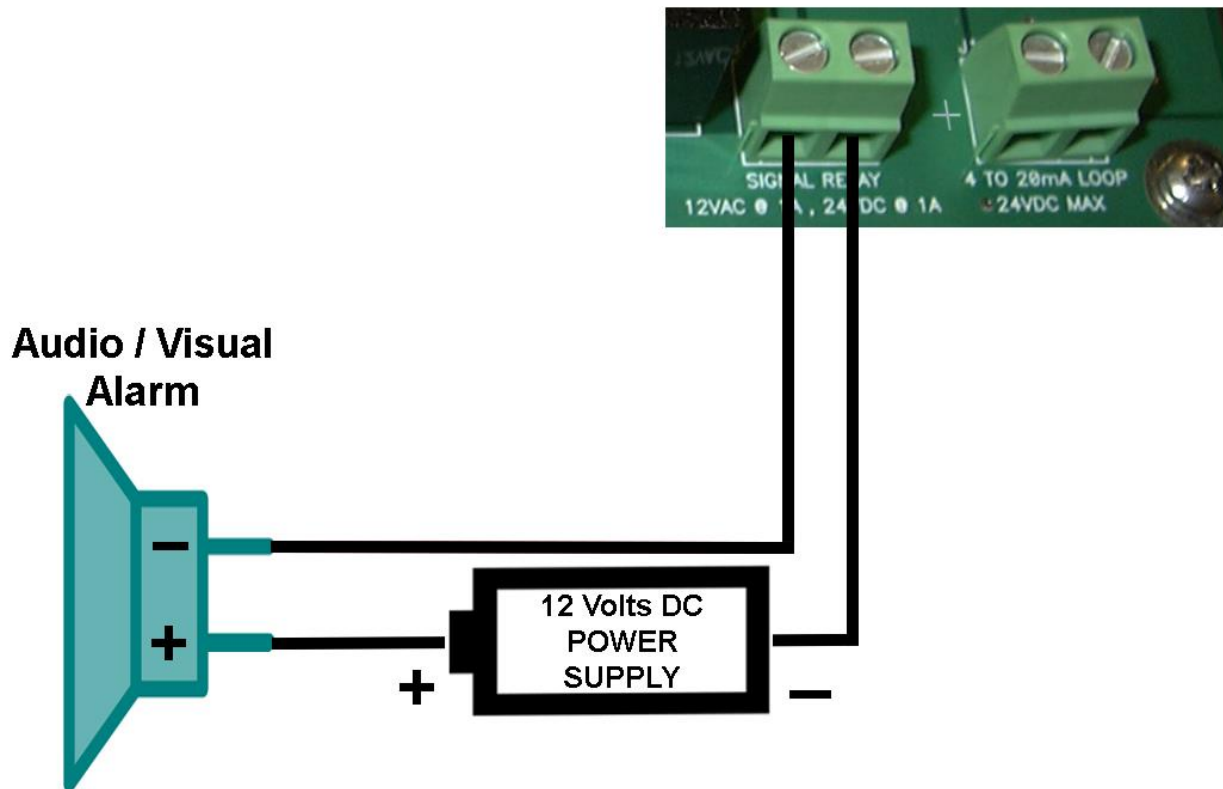

17 POTENTIAL INTERFERENCES

For some applications, the Jerome Mercury monitoring system may be installed in locations where foreign compounds are present. Depending on the foreign compounds present, in some cases erroneously high readings may occur.

In areas where chlorine gas is present, AMETEK Brookfield recommends the installation of a Jerome Chlorine Filter Kit (P/N Y990-0200). When installed, this filter will remove the chlorine gas from the sample stream so that the Jerome monitoring system can accurately measure levels of Mercury.

An Ammonia Filter Kit (P/N Y990-0202) is also available for locations where ammonia may be present.

For pricing and delivery information on the chlorine and ammonia filters, contact Jerome Sales.

NOTE: PLEASE READ THE DATA SHEETS INCLUDED WITH THE FILTERS FOR PROPER INSTALLATION AND USE OF THE CHLORINE AND AMMONIA FILTERS.

Filter data sheets are also available from customerservice.jerome@ametek.com



Ammonia Filter Kit for the 451

18 MERCURY MONITORING

Jerome® 451 Mercury Monitoring System

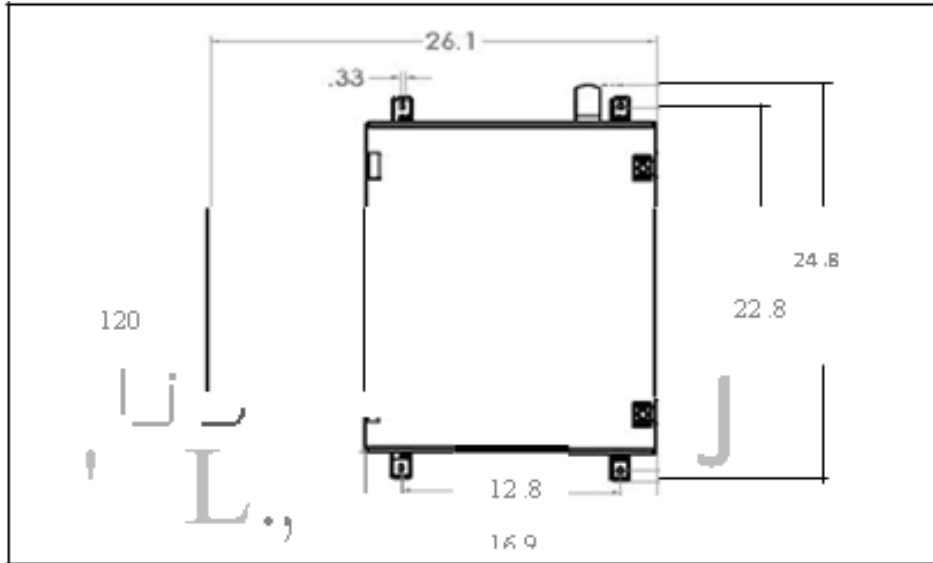

Specifications:

Resolution	0.001 at Range 0 to 0.1 ppm at Range 3
Detection Range	0.003-50 ppm
Precision	8% Relative Standard Deviation
Accuracy	Range 0: ± 0.005 ppm at 0.050 ppm Range 1: ± 0.05 ppm at 0.50 ppm Range 2: ± 0.3 ppm at 5.0 ppm Range 3: ± 2 ppm at 25 ppm
Flow Rate	150 cc/min or 0.15 l/min
Power	100-120 V~, 50/60 Hz maximum 6 amp draw with air conditioner on
Environmental Range	-40 to +50°C, weatherproof
Communication	Radio 900 MHz, 1 mile, line of sight JCS Lite 451 RS-232
Dimensions	8.5" W x 26" L x 21" H
Weight	52 lbs
Warranty	1 year, factory parts and labor

Standard Equipment:

Radio
Heater
Anemometer
Air Conditioner
Jerome® 431-X Mercury Vapor Analyzer

Optional Equipment:

Maintenance Kit for routine maintenance and upkeep
30 ppb Field Test Module for sensor calibration verification

*All specifications are preliminary and subject to change without prior notice.

19 MAINTENANCE

U.S. CUSTOMERS (Instruments sold within the continental United States)

Under continuous use, the 431-X gold film sensor is warranted to last for 3 months with a 15-minute sample interval and 24-hour regeneration interval or to last for 6 months with a 30-minute sample interval and 48-hour regeneration interval. During the 1-year warranty period, the sensor will be replaced free of charge with a maximum of 3 sensors during the 1-year period. Any sensors that require replacement after the warranty period or the beyond the 3 sensor maximum will be replaced at the cost to the customer.

AMETEK Brookfield offers an annual maintenance agreement, which would cover all repairs, calibrations, and sensors. Please contact customer service via phone or e-mail at customerservice.jerome@ametek.com for details and assistance.

In order to have continuous operation of the Jerome 451 in the field, AMETEK Brookfield offers a free loaner 431-X instrument during the 1-year warranty period or under the maintenance agreement. Please contact Customer Service via phone or e-mail at customerservice.jerome@ametek.com for details and assistance.

The VACUSHIELD filter (P/N 800-0065) is required to be replaced when the 431-X is recalibrated or after approximately 3 months of continuous use.

OUTSIDE THE U.S. CUSTOMERS (Instruments sold outside the continental United States)

Questions regarding maintenance and warranty support for instruments sold outside the continental United States need to be directed to your local representative or Customer Service via phone or e-mail at customerservice.jerome@ametek.com.

20 APPENDIX A: RADIO REPEATER SETUP

For users who have purchased the Radio Repeater Kit (P/N Y990-0278 Nano or P/N Y990-0203 Obsolete Spectra). Contact your AMETEK Brookfield technical sales representative for more information on the Radio Repeater Kit.

The Radio Repeater Kit contains the Radio Repeater (pictured below) and the software required to program the Radio Repeater. The Radio Repeater can be used to extend the distance between the base station and 451s/651s. For example, if you are placing 451s/651s over a large area with a high mountain nearby, you can increase radio range by locating a repeater on top of the mountain. For best results, use high gain directional outdoor antennas (P/N 200-0174) on the base station and 451s/651s, with the antennas pointed towards the repeater on the mountain. See **§8.1 Base Station Setup** for information about setting up outdoor/external antennas at the base station and see **§7.3 Outdoor/External Antenna Setup** for information about setting up outdoor/external antennas at the 451.

Line power of 100-240V AC, 50/60 Hz must be run to the marked connections of the terminal block in the radio repeater enclosure. Maximum current draw is 1 Amp.

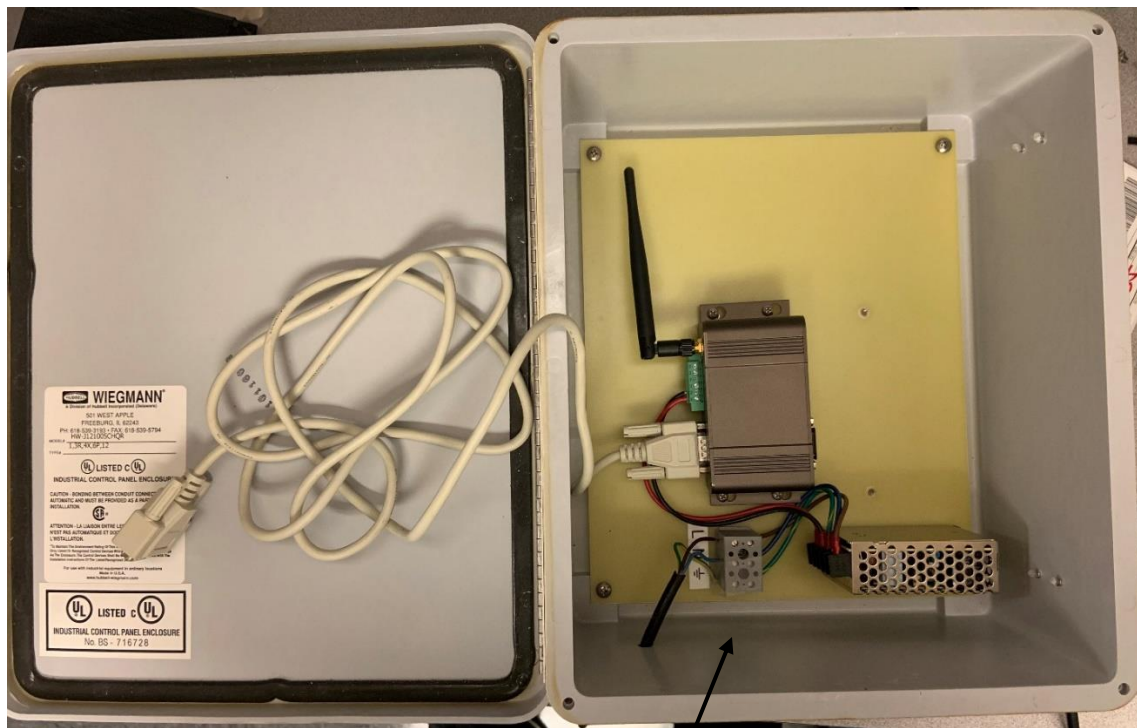

Radio Repeater with line power wired to the Terminal Block

Before the Radio Repeater can be used in the field, it must be programmed using the JMS software; see **§13.6 Repeater Setup** for details.

JMS Hardware Connection Details for Programming:

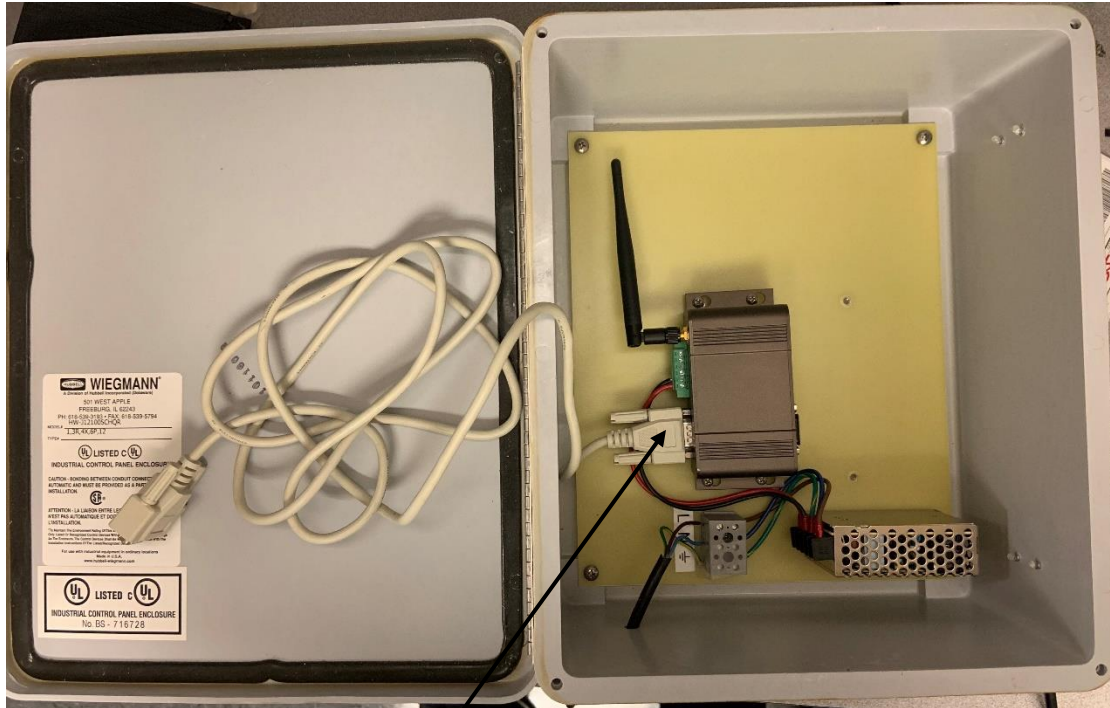

1. Connect the Male DB9 Connector of the included Serial cable (P/N 200-0038) to the DB9 DATA Port on the Nano Radio and connect the other end of the Serial cable to the JMS PC (when told to do so by JMS).
2. Make sure power is connected to the Radio Repeater.
3. Setup the repeater using JMS; see **§13.6 Repeater Setup**.
4. Disconnect the Radio Data cable from the Radio Repeater and install the Radio Repeater in the field for use.

To increase radio range, an external 451/651 antenna can be used. The standard 451/651 antenna is replaced with a lightning arrestor that YOU MUST GROUND. The external antenna is mounted above the 451/651 with a cable to the lightning arrestor. To provide additional lightning protection, install a lightning rod above the antenna to protect the system. See **§7.3 Outdoor/External Antenna Setup** for information about setting up outdoor/external antennas at the 451/651.

20.1 Example Nano Radio Network

See the example Nano radio network on the next page. Note, newer 451/651 firmware (V2.00+) is required to work with Nano radios. Spectra and Nano radios will not talk to each other.

To extend the distance between the base station and the 451/651s at addresses 5 and 6, the repeater at address 2 is used.

Instrument radios can also be configured as a repeater. In the example network, the 451/651 at address 3 is used to reach the 451/651 at address 4. To configure a 451/651 as a repeater, set the SYSTEM / FACTORY / RADIO menu item at the 451/651 to "NANO RP" (instead of "NANO"), and then set the NET ID, address, up address, and other radio parameters as appropriate using the SYSTEM / RADIO menu at the 451/651.

Check the Repeaters option in the Radio Settings pane of the System tab on the Settings form (**§13.2 Settings - System Options**).

Pay particular attention to the Up Address in this example. If there are no repeaters, then all the radio channels must be the same and there would not be any secondary channels.

NANO RADIO NETWORK EXAMPLE

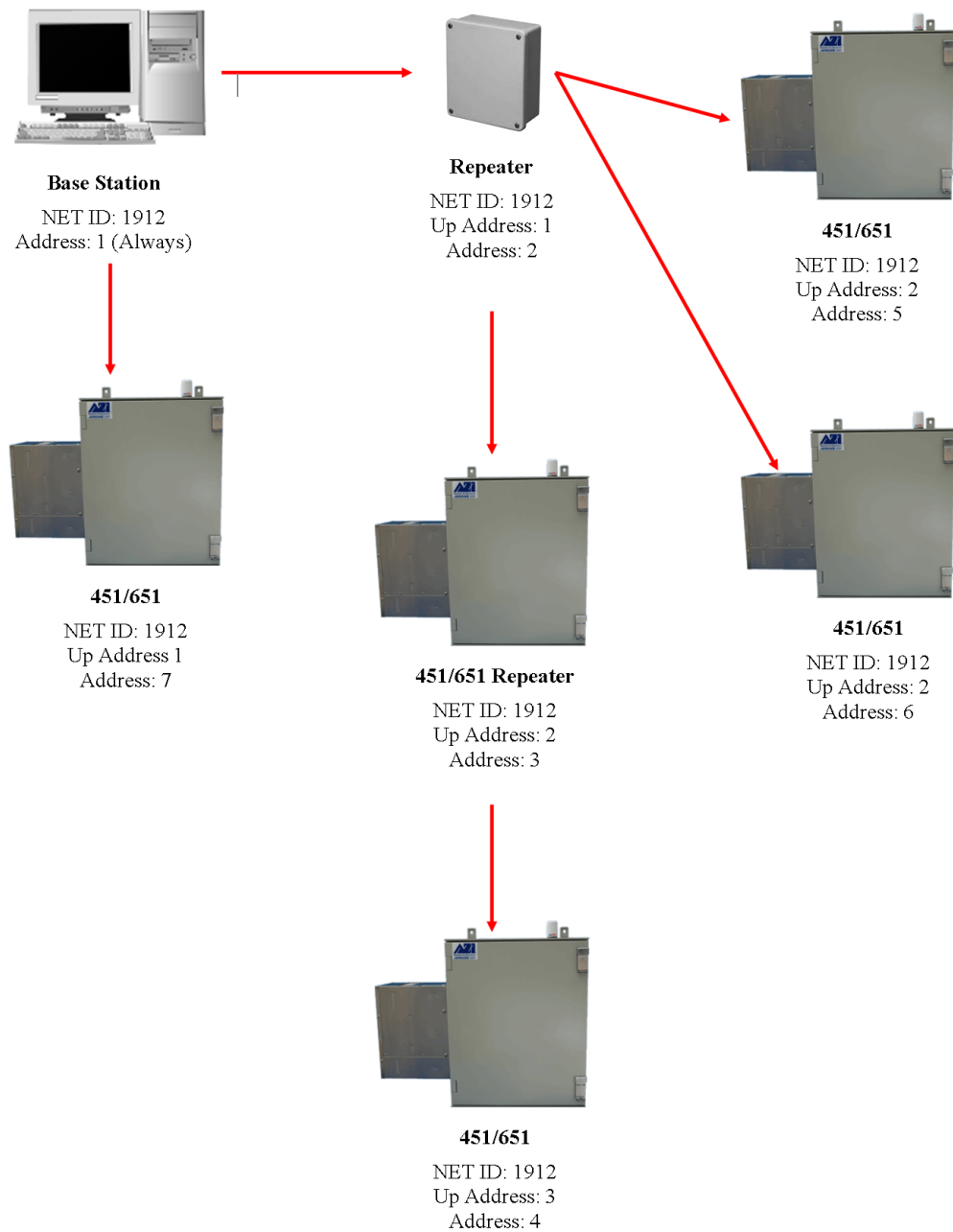

20.2 Example Spectra Radio Network (Legacy)

See the example Spectra radio network on the next page. Note, older 451/651 firmware (before V2.00) is required to work with Spectra radios. Spectra and Nano radios will not talk to each other.

To extend the distance between the base station and the 451/651s at addresses 5 and 6, the repeater at address 2 is used.

Instrument radios can also be configured as a repeater. In the example network, the 451/651 at address 3 is used to reach the 451/651 at address 4. To configure a 451/651 as a repeater, set the SYSTEM / FACTORY / RADIO menu item at the 451/651 to "SPECTRA RP" (instead of "SPECTRA"), and then set the NET ID, address, primary and secondary channels, and other radio parameters as appropriate using the SYSTEM / RADIO menu at the 451/651.

Pay particular attention to the radio channels in this example. If there are no repeaters, then all the radio channels must be the same and there would not be any secondary channels.

SPECTRA RADIO NETWORK EXAMPLE

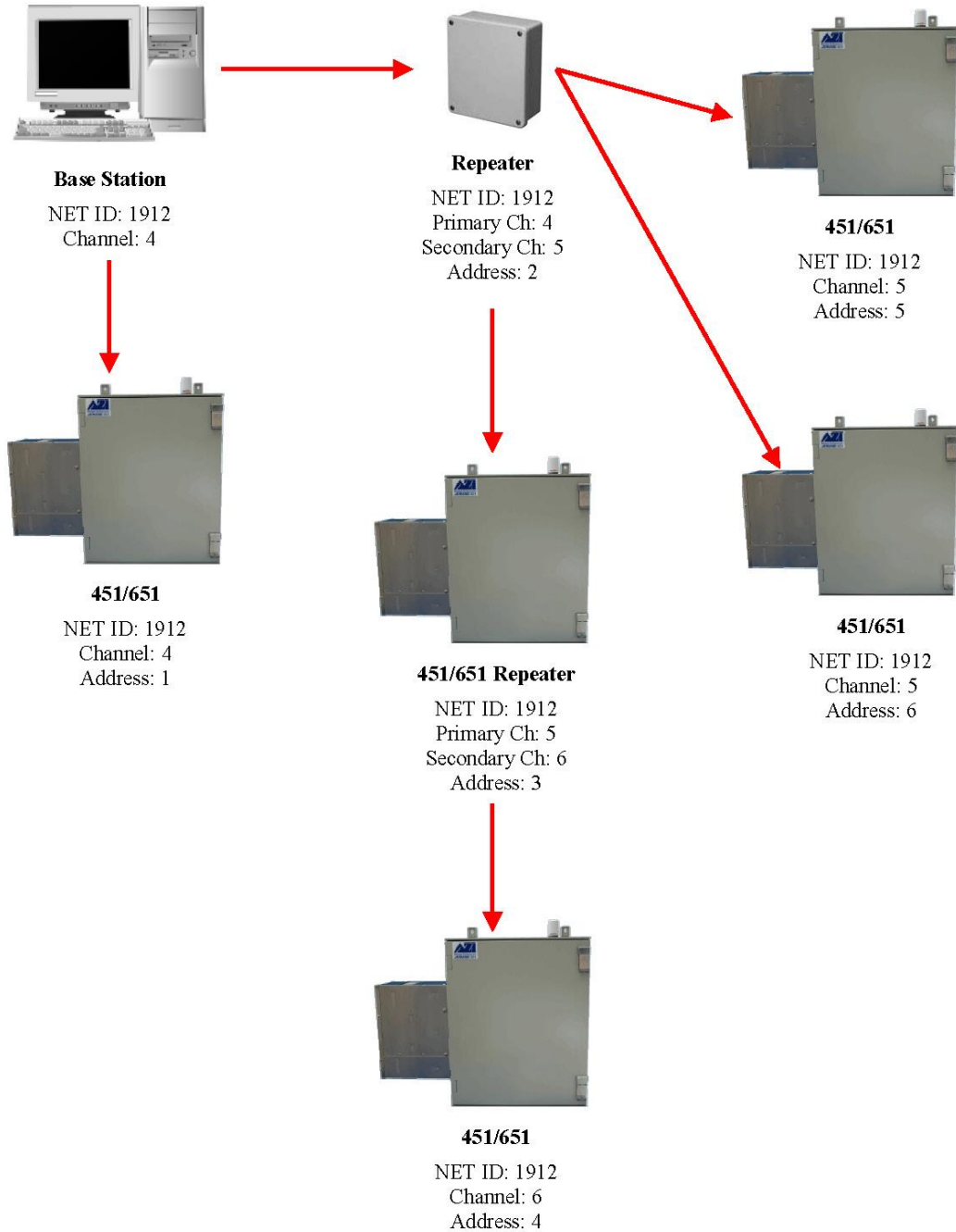

21 WARRANTY

AMETEK Brookfield (seller) warrants to buyer that Jerome products (excluding the 431-X sensor) delivered pursuant to this agreement, at the time of delivery, and for a period of one (1) year thereafter, to be free from defects in material or workmanship and shall conform to seller's specifications or such other specifications as seller has agreed to in writing. Under continuous use, the 431-X sensor is warranted to last for 3 months with a 15-minute sample interval and 24-hour regeneration interval or to last for 6 months with a 30-minute sample interval and 48-hour regeneration interval. For further information and maintenance agreements, contact Customer Service via phone or e-mail at customerservice.jerome@ametek.com. Internationally, call (602) 470-1414 or fax (480) 804-0656. Seller's obligations with respect to claims under this warranty shall be limited, at seller's option, either to the replacement of defective or non-conforming product or to an appropriate credit for the purchase price thereof subject to the provisions of seller's Warranty Policy as amended from time to time, said Policy being incorporated herein by reference.

Returned products under warranty claims will be shipped to seller's plant by buyer at buyer's expense and shall be accompanied by a statement of the reason for the return and an approved Return Material Authorization Number issued by seller. Buyer remains responsible for payment for products not accepted for warranty adjustment, handling costs, and freight costs associated therewith.

Notwithstanding the foregoing, no warranty shall be enforceable in the event that product has been subjected to environmental or stress testing by buyer or any third party without written approval of seller prior to such testing. Further, no warranty shall be enforceable if the alleged defect is found to have occurred because of misuse, neglect, improper installation, repair, alteration, accident, or improper return handling procedure by buyer.

Discontinued product is warranted only for a credit or replacement at seller's option.

THE EXPRESS WARRANTIES GRANTED ABOVE SHALL EXTEND DIRECTLY TO BUYER AND NOT TO BUYER'S CUSTOMERS, AGENTS, OR REPRESENTATIVES AND, EXCEPT FOR WARRANTY OF TITLE, IS IN LIEU OF ALL OTHER WARRANTIES, WHETHER EXPRESSED OR IMPLIED, INCLUDING ANY IMPLIED WARRANTIES OF FITNESS FOR A PARTICULAR PURPOSE AND MERCHANTABILITY, SUCH OTHER WARRANTIES BEING SPECIFICALLY DISCLAIMED BY SELLER. IN NO EVENT SHALL EITHER PARTY'S LIABILITY FOR ANY BREACH OR ALLEGED BREACH OF THIS AGREEMENT EXCEED THE TOTAL EXTENDED PRICE OR PRICES SHOWN ON UNFILLED ORDERS, NOR SHALL EITHER PARTY BE LIABLE FOR ANY SPECIAL, INCIDENTAL OR CONSEQUENTIAL DAMAGES RESULTING FROM BREACH OR ALLEGED BREACH.

Notwithstanding the foregoing, if any product covered by order(s) placed hereunder is designated as "developmental," "prototype" or "experimental," no warranty whatsoever except a warranty of title to component materials, will be applicable thereto and buyer shall indemnify seller for any claims for liability asserted seller in connection therewith.

The foregoing state the entire liability of seller in connection with products supplied hereunder.



AMETEK BROOKFIELD

TRADEMARK AND COPYRIGHT PROTECTION

©Copyright 2004-2021, AMETEK Brookfield. All Rights Reserved. Jerome, AMETEK Brookfield, AMETEK and the stylized AMETEK are all registered trademarks of AMETEK. All other trademarks are the property of their respective owners.

Microsoft is a registered trademark; Windows is a trademark of Microsoft Corporation.

AMETEK Brookfield
Jerome 451 Operation Manual
Part Number 700-0096 Revision 1.0

If you have any questions regarding the operation of this instrument, please call our toll-free number from the USA and Canada (800) 528-7411 or e-mail at customerservice.jerome@ametek.com.
Internationally, call (602) 470-1414 or fax (602) 281-1745.